

NTM

HOUSING FOR THERMAL CAMERAS IN AGGRESSIVE ENVIRONMENTS

MAIN FEATURES

Made of AISI 316L electropolished stainless steel

Germanium window

Cylindrical body enclosed by two 9mm-thick circular flanges

2 PG13,5 cable glands nickel-plated brass for external connections

IP66/IP67

Available accessories: heater and camera power supply

DESCRIPTION

This housing for thermal camera provides the vision also in complete darkness, fog, rain, smoke or for long-range distances.

The germanium window is external non-scratch treated, Hard Carbon Coating (DLC), and internal antireflection; the spectral range is from 7.5 to 14 μ m.

The AISI 316L stainless steel construction allows the installation in environments with highly corrosive external agents, such as marine, industrial or chemical environments.

The NTM housing can be installed on NXPTH Pan & Tilt head, to obtain a complete positioning system.



NTM

AVAILABLE MODELS

Model Number	Housing sunshield	Power supply 230Vac	Power supply 24Vac	Ø germanium window
NTM1K1000	✓	✓	–	55mm (2.1in)

TECHNICAL DATA**GENERAL**

Constructed from electropolished stainless steel (austenitic alloy stainless steel, corrosion and heat resistant according to the following standards):

AISI 316L

UNI 6900-71: X 2 Cr Ni Mo 17 12 2

DIN 17006: X 2 Cr Ni Mo 17 13 2

N° werkstoff 1.4404

AFNOR: Z2 CND 17-12

BSI: 316S11

The screws utilised are in austenitic alloy stainless steel, corrosion and heat resistant according to the following standards:

- UNI 6900: X 5 Cr Ni Mo 1712
- AISI: 316
- ISO quality: A4
- Resistance class ISO: 80

UNI: Ente Nazionale Italiano di Unificazione, AISI: American Iron and Standard Institute, DIN: Deutsche Industrie Normen, AFNOR: Association Française de Normalisation, BSI: British Standard Institution, ISO: International Organization for Standardization.

MECHANICAL

Cable glands: 2xPG13.5 (nickel-plated brass for external connections)

External body polishing

Flange thickness: 9mm (front/back)

Gaskets: High sealing O-ring

Internal usable area (WxH): 88x86mm (3.5x3.4in)

Internal usable length (without accessories): 334mm (13.1in)

Internal usable length (with heater and/or power supply): 245mm (9.6in)

Unit weight: 6kg (13.3lb)

Germanium window

- Dimensions (Ø): 72mm (2.8in) (external), 55mm (2.1in) (internal)
- Thick: 2mm (0.07in)
- External scratch-resistant treatment: Hard Carbon Coating (DLC)
- Internal antireflection treatment
- Spectral range: 7.5µm ÷ 14µm
- Medium transmittance (7.5µm ÷ 11.5µm): 94%
- Medium transmittance (11.5µm ÷ 14µm): 90%

ELECTRICAL

Heating (Ton 15°C±3°C (59°F ±5°F), Toff 22°C±3°C (77°F±5°F))

- Power supply/Consumption: IN 12Vdc/24Vac, 20W max
- Power supply/Consumption: IN 120/230Vac, 40W max

Camera power supply

- IN 100-240Vac - OUT 12Vdc, 50/60Hz, 1A
- IN 230Vac - OUT 24Vac, 50/60Hz, 400mA

ENVIRONMENT

Indoor/Outdoor

Operating temperature with heating: -20°C / +60°C (-4°F / +140°F)

CERTIFICATIONS

CE EN61000-6-3, EN60065, EN50130-4

IP66/IP67 EN60529

ACCESSORIES

OHEH06B Heater 120/230Vac

OHEH05B Heater 12Vdc/24Vac

ONXPS1B Wide range power supply for camera IN 100-240Vac - OUT 12Vdc, 1A

ONXPS2B Camera power supply IN 230Vac - OUT 24Vac, 400mA

RELATED PRODUCTS

NXPHT Stainless steel Pan & Tilt

BRACKETS AND ADAPTORS

NXWBS1 Stainless steel wall bracket with joint

SPARE PARTS

ONXMMAN Maintenance kit for NXM

OSPAVIPNXM Complete blade for VIPNX wiper

ONTMFA Front cover complete with germanium window

PACKAGE

Model Number	Weight	Dimensions (WxHxL)	Master carton
NTM1K11000	7.3kg (16.1in)	24.5x24.5x62cm	-

TECHNICAL DRAWINGS

Sizes in millimeters.

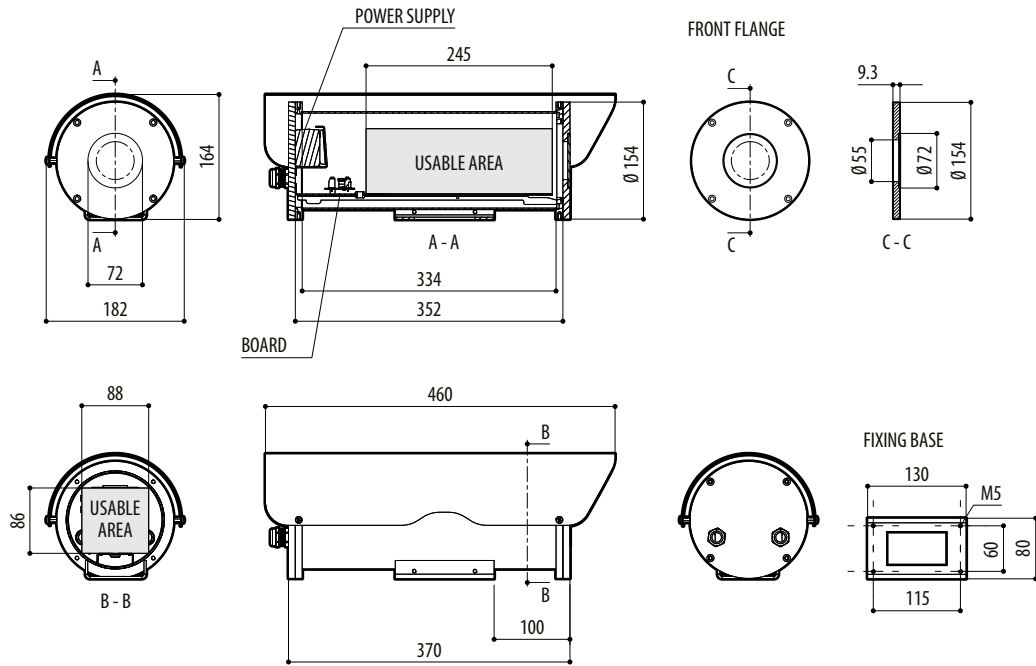

NTM

