

V920D SERIES ROUGHNECK CAMERA DOME



- Rugged construction for harsh indoor or outdoor environments
- On-screen menus for easy setup and operation
- 750 TV lines resolution
- D-WDR (Digital Wide Dynamic Range)
- True day/night camera with a built-in varifocal autoiris lens
- 0.01 lux low light capabilities @ 50 IRE
- Privacy masking provides the ability to block out selected regions of a scene; motion detection
- 24 VAC or 12 VDC
- IP66 rated; heater provides all-weather protection
- IK10 rated for impact protection
- Surface mounting on wall or ceiling; pendant and in-ceiling mounting options

Overview

Vicon's V920D Roughneck® Camera Dome is designed for demanding security installations and harsh and destructive environments. This fixed indoor/outdoor camera dome delivers crisp clear images to fit any installation need.

The V920D dome is constructed of die-cast aluminum with a high-impact polycarbonate plastic dome. It includes an integral high-resolution (750 TVL) day/night camera and 2.8-12 mm autoiris varifocal lens. Digital Noise Reduction improves image quality and minimizes video interference. The digital WDR improves detail in bright and low light areas of an image.

The V920D is designed for easy installation. It can be mounted on a wall, ceiling or standard 4 x 4 electrical box. With an adapter, it can also be pendant mounted

on a wall mount or in-ceiling. The camera position is adjustable to any view required. An on-screen display provides an extensive menu system to customize many camera settings. The camera accepts 12 VDC and 24 VAC; NTSC and PAL versions are available.

In order to adapt to constantly changing outdoor lighting conditions, the V920D features an autoiris lens to protect from damage induced by direct sunlight. The true day/night camera also includes a removable IR-cut filter for superior image quality around the clock. For protection against the elements, the camera dome is IP66 rated with a vandal-proof casing to withstand rain, dust, and vandalism; it is secured by tamperproof screws. The heater (24 VAC only) further enhances the dome's performance and reliability in extremely weather conditions. The camera dome provides 3-axis adjustment for any angle of view.

Model	V920D-N312/V920D-N312-P
Image Sensor:	1/3-inch Super HAD II 960H CCD; 2:1 interlace
Picture Elements:	NTSC: 1028 (H) x 508 (V) PAL: 1028 (H) x 596 (V)
Sensitivity:	Color: 0.1 lux) B/W: 0.01 lux; Slow Shutter: 0.001 lux) @f/1.2, 50 IRE
Resolution:	750 TV Lines
Synchronization:	Internal/Line Lock (Phase Control)
Signal-to-Noise Ratio:	More than 50 dB (AGC off)
Electronic Shutter Speed:	1/60 (1/50 PAL) ~ 1/100,000
Digital Zoom:	0 - X255; supports digital PTZ
Day/Night Performance:	True day/night (IR cut filter)
Video Output:	1.0 V p-p @ 75 ohms, composite

Lens

Focal Length:	2.8-12 mm (4X zoom)
Max. Aperture:	f/1.2
Iris:	Varifocal DC Autoiris
Zoom/Focus Adjust:	Screw lever adjustable
Horizontal Field of View:	91° - 28°

Camera Settings

Image Settings:	Digital Image Effects: vertical flip and sharpness. White balance. Exposure. Electronic shutter speed. Day/night mode. BLC (Backlight Compensation). Digital WDR. Digital zoom. Dynamic Noise Reduction (2D+3D). Motion detection. Sense-Up (X256). Privacy masking (15). White pixel detection. Defog. Camera name/ID display. Language selection.
Camera Control:	Joystick control of OSD menu; RS-485

Mechanical and Electrical

Construction:	Die-cast aluminum base; polycarbonate plastic clear dome; tamperproof screws
Camera Angle of Adjustment:	3-axis adjustment, pan, tilt and roll (azimuth): 355° pan; 70° tilt; 355° rotation
Mounting:	Surface mount. Mounting accessories available for pendant/wall and in-ceiling.
Dimensions:	6.06 in. (154 mm) (Diam) x 5.0 in. (127.4 mm) (H), 4.3 in. (109.97 mm) (Dome Diam)
Weight:	2.5 lb (1.1 kg)
Input Power:	12 VDC; 24 VAC, ±10%
Current:	250 mA; heater (24 VAC only): 0.8 A
Power Consumption:	3.0 W; heater (24 VAC only): 20 W

Environmental

Operating Conditions:	Temp: -40 to 122° F (-40 to 50° C) with heater; 14 to 122° F (-10 to 50° C) without heater Humidity: up to 90%, non-condensing Heater: 41° F (5° C) (ON)/59° F (15° C) (OFF); tolerance: ±5° C
Approvals:	UL, FCC Class A, CE, IP66, IK10
Warranty:	3 years

Data Sheet Number: V258-11-00
 Dated: 11/2014
 Vicon Data Sheet Number: 8009-7258-11-00
 Specifications subject to change without notice.

Vicon, Roughneck and their logos are registered trademarks of Vicon Industries Inc.
 EXview is a trademark of Sony Corporation.
 Copyright © 2014 Vicon Industries Inc. All rights reserved.

Controls and Connectors

External Controls:	Focus, Zoom: control levers
Connectors:	Power: 12 VDC/24 VAC: 2-pin wire. Video output: BNC. Camera Control: OSD, joystick switch; RS-485. Fixed lens mount.

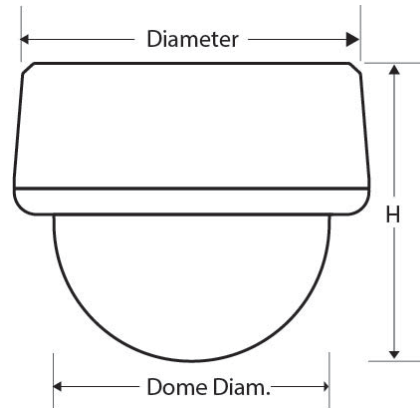

Dimensional Drawing (in.)

Model Number	Descriptions
V920D-N312	Vandal-proof indoor/outdoor camera dome; includes integral day/night camera with 2.8-12 mm varifocal autoiris lens; NTSC
V920D-N312-P	Vandal-proof indoor/outdoor camera dome; includes integral day/night camera with 2.8-12 mm varifocal autoiris lens; PAL

Model Descriptions

Model Number	Description
V920-PH	Pendant housing used to convert V920D to pendant mounting; it can then be used with a variety of wall mounts
V920D-ICD	In-ceiling mounting kit for dropped ceiling
V920D-ICH	In-ceiling mounting kit for hard ceiling
Surge Protectors	Refer to datasheet

Mounting Accessories