

ROUGHNECK™

V910 Series Mounting Accessories

Vicon's Roughneck® V910 Camera Dome series offers several mounting options to increase its versatility. These include in-ceiling mounting kits for both dropped and hard ceilings and a pendant housing adapter kit that allows the V910 to mount on a variety of mounting options.



V910-ICD In-Ceiling Mounting Kit

- For dropped ceiling installation
- Kit contains mounting bracket and all required hardware
- Plate Diameter: 7 in. (177.8 mm)
- Bracket: 9.25 in. (235 mm) x 4.75 in. (120.7 mm)
- Rails: 19 in. (483 mm) long; extend to fit 24 in. (609.6 mm) ceiling tile
- Height: 4.3 in. (109.2 mm)
- Weight: 2.75 lb (1.25 kg)

Dimensional Data

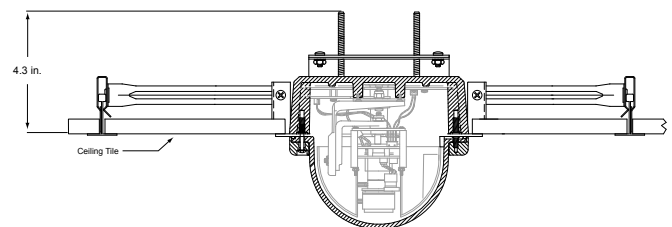

V910-ICH In-Ceiling Mounting Kit

- For hard ceiling installation
- Kit contains mounting bracket and all required hardware
- Plate Diameter: 7 in. (177.8 mm)
- Bracket Height: 2 in. (51 mm)
- Height: 2.5 in. (63.5 mm)
- Weight: 0.72 lb (0.33 kg)

Dimensional Data

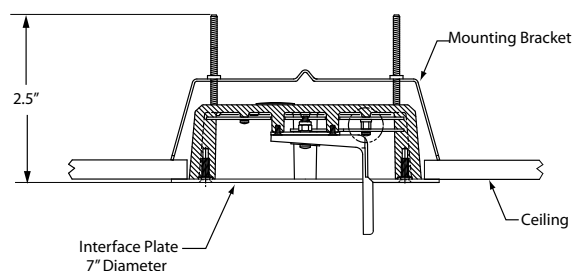

V910-PH Pendant Housing



V910 shown with V910-PH Pendant Housing and SVVT-UWM Indoor/Outdoor Wall-Mount

- Pendant Housing adapter kit allows the V910 camera dome to be mounted to the full line of SVFT mounting accessories
- Construction: Cast aluminum
- Diameter: 5.75 in. (146 mm)
- Height: 2.5 in. (63.5 mm)
- Weight: 0.9 lb (0.41 kg)

Dimensional Data

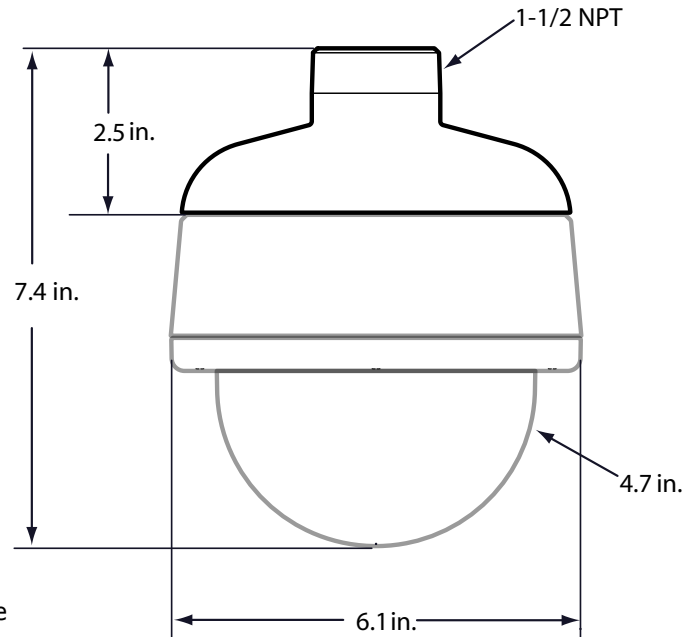

Wall Mount SVFT-WM



- Wall mounting camera domes
- Cast aluminum construction
- 1-1/2-inch NPT-F pipe thread
- Height: 4.9 in. (124 mm)
- Width: 3.5 in. (89 mm)
- Depth: 7.5 in. (191 mm)
- Weight: 1.4 lb (0.6 kg)

Dimensional Data

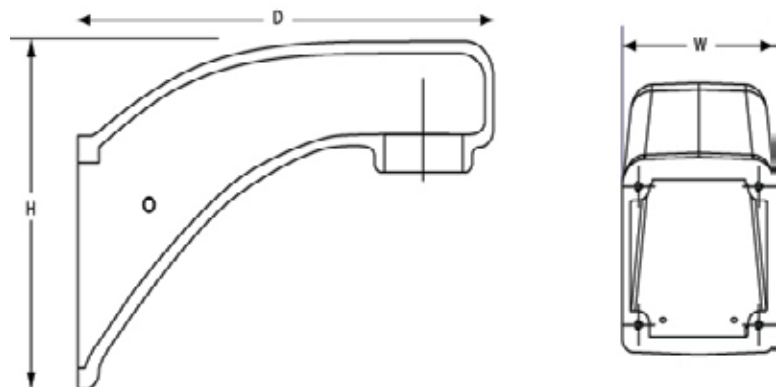

- Full datasheet available for more details.

Application

- Requires the V910-PH for mounting

Data Sheet Number: V137-50

Dated: 07/2011

Vicon Data Sheet Part Number: 8009-7137-50-00

Specifications subject to change without notice.

Vicon, Roughneck and their logos are registered trademarks or trademarks of Vicon Industries Inc.

Copyright © 2011 Vicon Industries Inc. All rights reserved.

Wall Mount SVFT-UWM



Dimensional Data

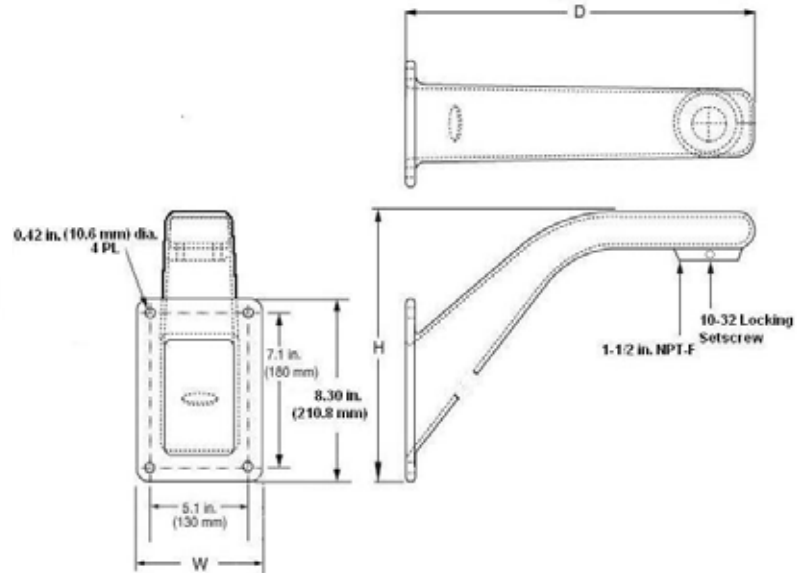

- Wall mounting camera domes
- Cast aluminum construction
- 1-1/2-inch NPT-F pipe thread
- Height: 11.6 in. (295 mm)
- Width: 6.3 in. (160 mm)
- Depth: 14.6 in. (371 mm)
- Weight: 4.5 lb (2.0 kg)

Application

- Requires the V910-PH for mounting

- Full datasheet available for more details.

Ceiling Mount SVFT-UCM



Dimensional Data

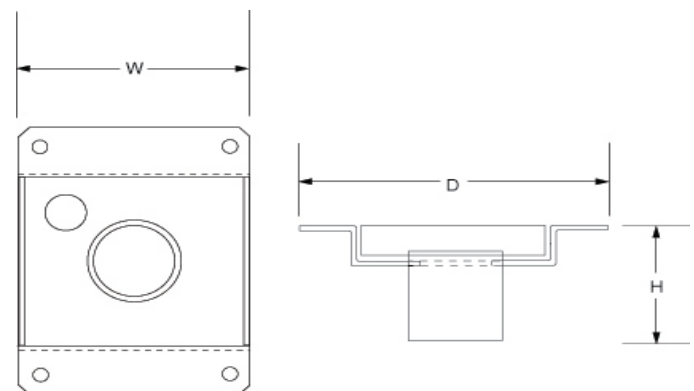

- Ceiling mounting
- Carbon steel construction
- 1-1/2-inch NPT-F pipe thread
- Height: 3.0 in. (76 mm)
- Depth: 9.1 in. (231 mm)
- Width: 6.0 in. (152 mm)
- Weight: 3.3 lb (1.5 kg)

Application

- Requires the V910-PH for mounting

- Full datasheet available for more details.

Parapet Mount SVFT-UPM-1



- Designed specifically for parapet mounting camera domes
- Aluminum and steel construction
- 1-1/2-inch NPT-F pipe thread
- Height: 37 in. (940 mm)
- Width: 27 in. (686 mm)
- Load Rating: 40 lb (18 kg)
- Weight: 7.6 lb (3.4 kg)

Application

- Requires the V910-PH for mounting

Dimensional Data

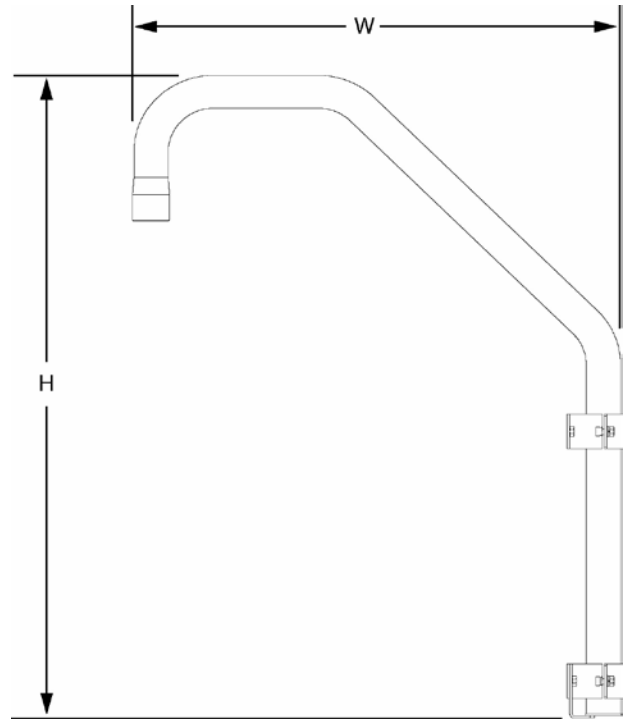

- Full datasheet available for more details.

Roof Mount SVFT-URM-1



- Designed specifically for roof mounting camera domes
- Aluminum and steel construction
- 1-1/2-inch NPT-F pipe thread
- Height: 37 in. (940 mm)
- Width: 35 in. (889 mm)
- Load Rating: 50 lb (23 kg)
- Weight: 22.5 lb (10.2 kg)

Application

- Requires the V910-PH for mounting

Dimensional Data

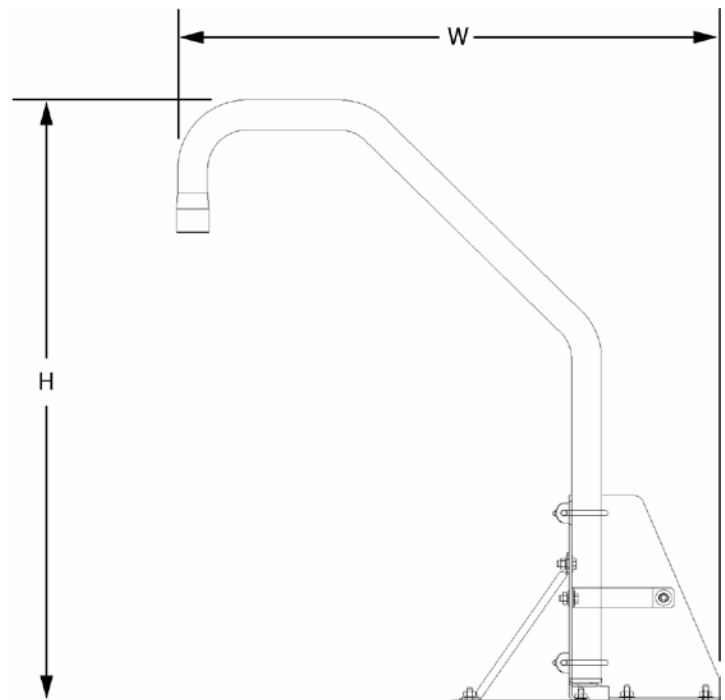

- Full datasheet available for more details.

Corner Mount Bracket V24CMB

Dimensional Data



- Designed for corner mounting SVFT wall mounts
- Corrosion-protected steel construction
- Height: 6.6 in. (168 mm)
- Width: 12 in. (305 mm)
- Weight: 8.2 lb (3.7 kg)

Application

- For corner mounting SVFT-WM and SVFT-UWM wall mounts

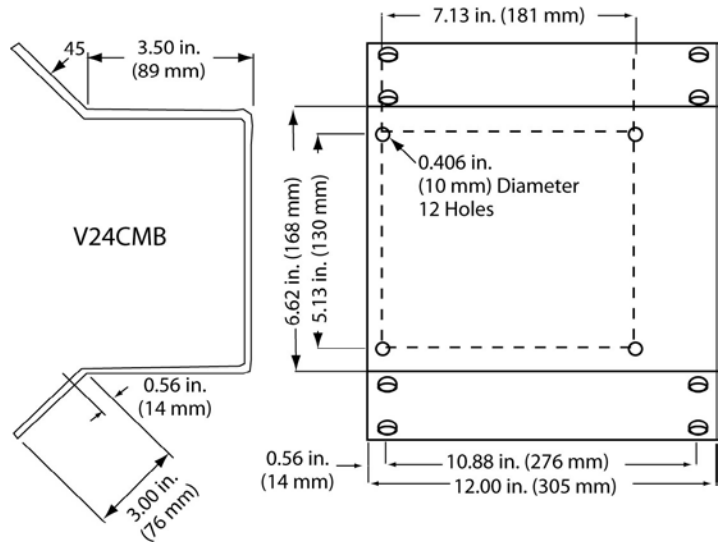

Pole Mount Adapter V20B-A Series

Dimensional Data



- Designed for pole mounting SVFT wall mounts
- Available with aluminum or stainless steel construction
- Fits 4 - 10 in. diameter poles
- Height: 12.75 in. (324 mm)
- Width: 8 in. (203 mm)
- Depth: 3.5 in. (89 mm)
- Weight: Aluminum - 3.7 lb (1.7 kg); steel - 11 lb (5 kg)

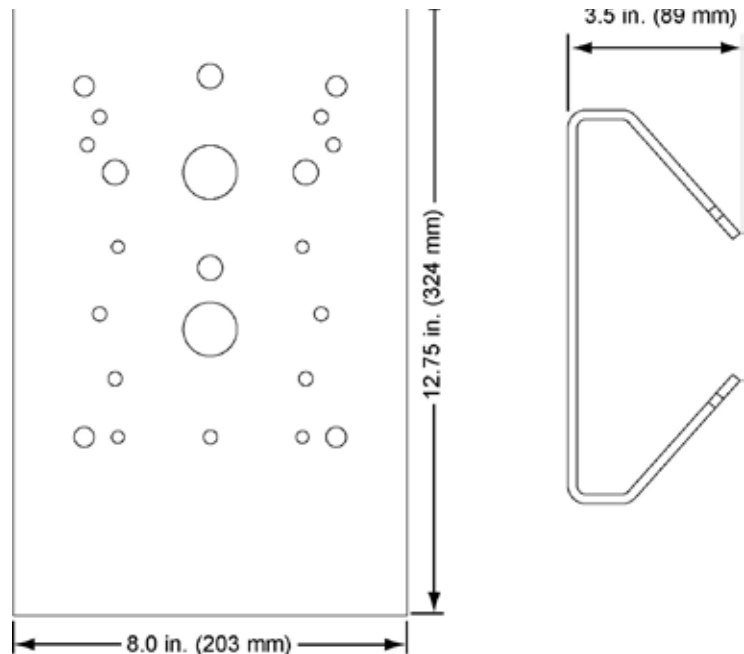

- Full datasheet available for more details.

Application

- For pole mounting SVFT-WM and SVFT-UWM wall mounts