



PRODUCT SPECIFICATION

MODEL: V1100AWM

PRODUCT CODE: 1876-06

DESCRIPTION: LIGHT-DUTY, INDOOR, ADJUSTABLE WALL MOUNT

- Attractive light gray color
- High-impact plastic
- Adjustable head
- Conceals cabling

The V1100AWM Wall Mount is a light-duty mount. It is constructed of high-impact plastic, is light gray in color, and is designed to support camera/housing combinations weighing individual locking knobs for horizontal and vertical movement and can be set for any normal camera angle. The v1100AWM may be mounted to a standard outlet box, which allows convenient, concealed cable routing to the mount. The body of the mount is hollow, allowing wiring to be concealed as it is run from the wall to the camera. It is intended for indoor use.

NOTES	SPEC NO.	REV.	SEC.
SUPERSEDES PRODUCT SPECIFICATION 631-588	631	198	7



V1100MM MONITOR MOUNT

TECHNICAL INFORMATION

MECHANICAL

Dimensions: See Figure 1.
 Weight: 0.7 lb (0.3 kg).
 Construction: High-impact plastic
 Finish: Light gray
 Load Rating: 7.5 lb (3.4 kg)

Mounting: Two no. 10 screws. Optional mounting to the standard outlet box with 6-32 screws.

Shipping Dimensions: Height: 3.0 in. (7.6 cm).
 Width: 4.6 in. (11.7 cm).
 Length: 9.1 in. (23.1 cm)..

Shipping Weight: 8.0 lb (0.4 kg).

Shipping Volume: 0.7 ft³(0.002 m³)

CONTRACTORS' SPECIFICATION

ADJUSTABLE WALL MOUNT

The wall mount shall be an adjustable indoor unit, 8.3 inches (21 cm) long, be of high-impact plastic construction an weigh 0.7 lb (0.3 kg). Height and width shall not exceed 4.5 in. (11.4 cm) and 2.9 in. (7.4 cm), respectively. It shall have a load rating of 7.5 lb (3.4 kg). The head shall be manually adjustable over a tilt range of ±90°. Provisions shall be incorporated for mounting directly to a standard outlet box.

The wall mount shall be Vicon's model V1100AWM.

Product specifications subject to change without notice.
 Copyright © 1999 Vicon Industries Inc. All rights reserved.

Vicon part number 8006-7631-01-00
 Vicon and its logo are registered trademarks of Vicon Industries Inc.

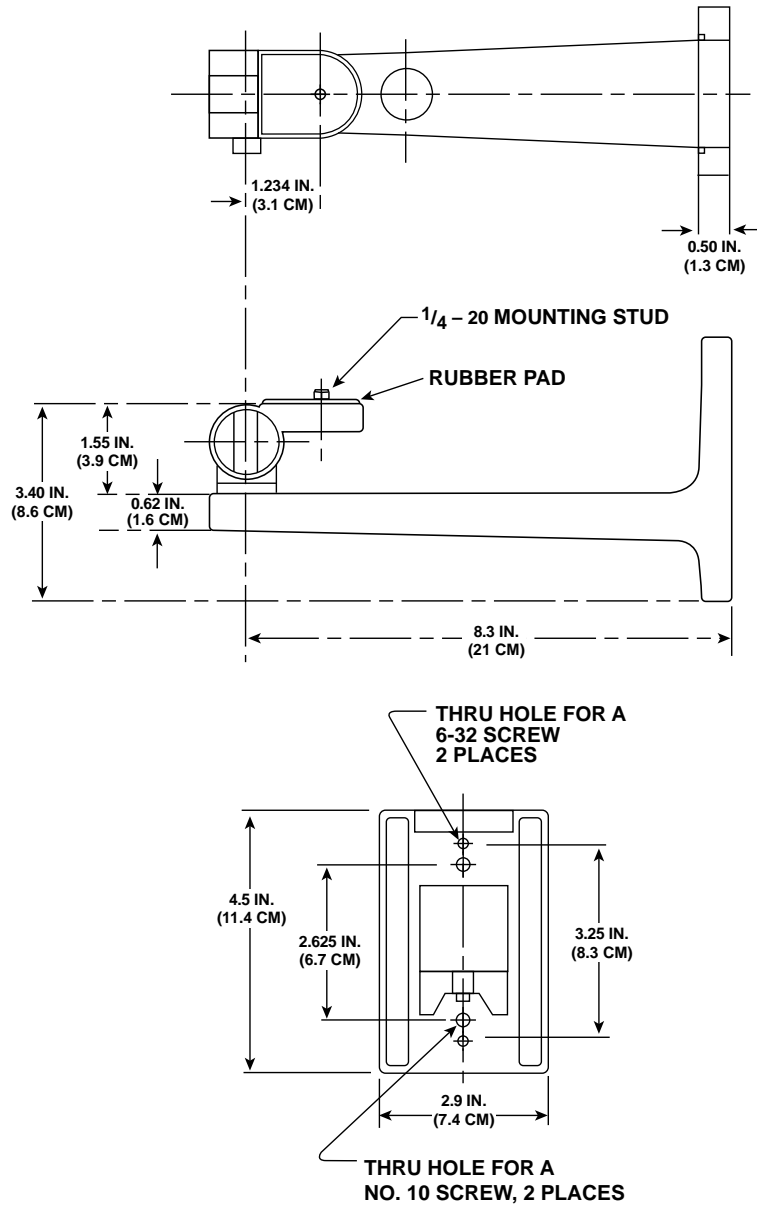

Figure 1
V1100AWM Wall Mount Dimensions