

CFVS1327-LP

Super high resolution Fixed dome 650TVL (960H Sensor technology) with varifocal lens

VANDERBILT



Attractive high resolution dome camera for either ceiling or wall mounting, complete with smoked protective bubble. Includes service monitor connection and cable for easy local setup. Designed for indoor applications where discreet, unobtrusive surveillance is demanded. The electronic design is based on latest 960H sensor technology delivering detailed video resolution up to 700 TVL

Key features include:

- Discreet and compact design
- Super high resolution max. 700 TVL (960H sensor technology)
- Varifocal auto-iris lens F1,4
- Mechanical IR cut filter (Day/Night model)
- Switchable BLC (6 predefined fields with remote software)
- Dual voltage 12 V DC/24 V AC (line-lock phase adjustment)
- Full X, Y and Z axis adjustment for wall and ceiling mount
- Smoked protective lower bubble
- Easy setup via setup software with local remote-setup port

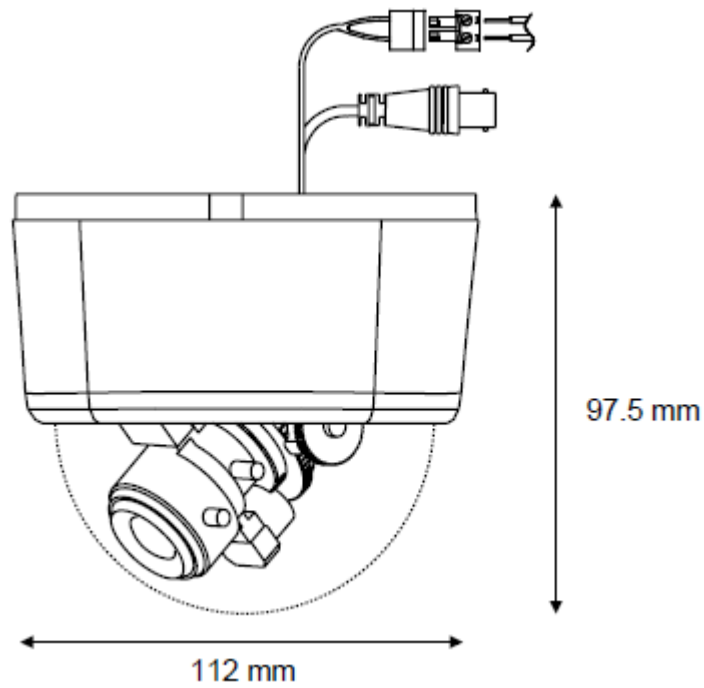

Technical data

CFVS1327-LP

General

Fixed Dome	High Resolution Day/Night
Image sensor	1/3-inch EXVIEW HAD CCD II 976 (H) x 582 (V)
Horizontal resolution	max. 700 TV lines, typ. 650 TV lines
Minimum illumination (at 50 IRE)	
Clear bubble	0.29 Lux (colour) / 0.21 Lux (mono)
Smoked bubble	0.53 Lux (colour) / 0.43 Lux (mono)
S/N ratio	> 50 dB
Electronic shutter (AES)	1/50 to 1/100000 s
Backlight compensation	ON or OFF (software allows 6 zones)
Gain control	AGC ON or OFF (software allows 18 - 30 dB)
Sync system	Internal / line lock (AC only)
White balance	Automatic
Bubble type	Smoked

Video output	
TV system	PAL, 2:1 interlace 50 Hz vertically, 15,625 Hz horizontally
Signal (composite)	1 Vpp, 75 Ohm, BNC
Local service monitor output	Yes (cable included)
Lens details	
Focal length	3.7 - 12 mm
Focus type	Adjustable
Maximum relative aperture	F1.4 – 2.8
Iris	Direct drive auto-iris
Horizontal angle of view	22.7 – 76.9°
Minimum object distance	0.5 m
Electrical	
Supply voltage	12 V DC / 24 V AC, 2.5 W
RS232 remote setup (optional)	Yes
Mechanical	
Dimensions (Ø x H)	112 x 97.5 mm

Details for ordering

Type	Part no.	Designation	Weight*
CFVS1327-LP	V54561-C108-A100	1/3-inch CCD Varifocal Dome, High Resolution Day/Night 12 V DC/24 V AC, 2.5 W	0.3kg

