

CCDA1425 / CCDA1435

Speed Dome Camera Accessories

VANDERBILT



CCDA1425
CCDA1435

The CCDA1425/1435 high-speed dome cameras are supported by an extensive range of accessories that will provide for most mounting requirements, whether the cameras have to be mounted indoors or outdoors. Alternative dome bubbles are available for all dome housings.

Key features include:

- Weatherproof housing
- Vandal-proof weatherproof housing
- Indoor ceiling surface mount
- Indoor flush ceiling mount
- Wall mounts (indoor and outdoor)
- Wall mount with junction box
- Ceiling mount (indoor and outdoor)
- Indoor pendant mount adapter
- Corner mount adapter
- Extension pole
- Smoked bubble
- Compact power supply unit
- Compact power supply unit for outdoor applications

Product information



CCDA1425-WPH

CCDA1425-WPH Weatherproof housing (V2GF1192-8BA)

This weatherproof housing enables the outdoor installation of the CCDA1425/1435 Speed Domes. Incorporating a temperature management, the outdoor housing is designed for operation in temperatures ranging from -30 – +50 °C. Including a heater and fan the housing is weatherproof to IP66.



CCDA1425-VRH

CCDA1425-VRH Vandal-proof weatherproof housing (V2GF1192-8CA)

The vandal-proof weatherproof housing is basically identical with the housing type CCDA1425-WPH. This outdoor housing is additionally equipped with a impact-proof bubble (800 kg) and tamper-resistant screws. Incorporating a temperature management, the outdoor housing is designed for operation in temperatures ranging from -30 – +50 °C. Including a heater and fan the housing is weatherproof to IP66.



CCDA1425-SM

CCDA1425-SM Indoor ceiling surface mount (V2GF1192-8BB)

This indoor ceiling mount includes a clear bubble that will prevent the ingress of dust when the CCDA1425/1435 Speed Dome is installed indoors. This ceiling mount attaches directly to the surface of a flat ceiling.



CCDA1425-FM

CCDA1425-FM Indoor ceiling flush mount (V2GF1192-8BC)

This indoor flush ceiling mount includes a clear bubble that will prevent the ingress of dust when the CCDA1425/1435 Speed Dome is installed indoors. The housing enables the domes to be recessed into a hole cut into the ceiling.



CCDA1425-WM

CCDA1425-WM Wall mount (V2GF1192-8BE)

This wall mount attaches directly to a flat upright wall and includes a mounting flange with a standard 1½-inch NTP threaded pipe. This simple wall mount is compatible with the weatherproof outdoor housing CCDA1425-WPH.



CCDA1425-WMI

CCDA1425-WMI Indoor wall mount (V2GF1192-8BQ)

This indoor wall mount attaches directly to a flat upright wall. It can be used to mount a dome camera indoors in conjunction with an indoor ceiling surface mount (2GF1192-8BB).



CCDA1425-WMJ

CCDA1425-WMJ Wall mount with junction box (V2GF1192-8BF)

This wall mount attaches directly to a flat upright wall and includes a mounting flange with a standard 1½-inch NTP threaded pipe. The integrated junction box provides perfect cable connectivity and servicing / maintenance capability. The “internal” cabling to the dome camera is established via a system cable that is delivered together with the weatherproof housing. This wall mount with junction box is compatible with the weatherproof outdoor housing CCDA1425-WPH.



CCDA1425-PM

CCDA1425-PM Indoor/outdoor pendant mount (V2GF1192-8BG)

This ceiling pendant mount is a perfect solution for mounting the weatherproof housing CCDA1425-WPH to any wood, metal, plaster, drywall, or other hard ceiling. The mounting assembly includes a ceiling flange and a standard 1½-inch NTP threaded pipe for mounting the weatherproof housing. The assembly can be used in beam/pendant installations.



CCDA1425 PMI

CCDA1425-PMI Indoor pendant mount adapter (V2GF1192-8BN)

This adapter is used to attach a dome camera to a ceiling pendant mount. It is only designed for installation indoors and only for use in conjunction with a dome camera and indoor surface mount CCDA1425-SM.



CCDA1425-PMA

CCDA1425-PMA Pole mount adapter (V2GF1192-8BD)

This pole mount adapter is used to fix the wall mount CCDA1425-WM or CCDA1425-WMJ onto a pole (max. pole diameter 150 mm).



CCDA1425-CMA

CCDA1425-CMA Corner mount adapter (V2GF1192-8BH)

This corner mount adapter can be used to fix the wall mounts CCDA1425-WM or CCDA1425-WMJ on a right angled wall corner.



CCDA1425-EP

CCDA1425-EP Extension pole (V2GF1192-8BJ)

The extension pole increases the length of wall and pendant mounts by 0.5 m. For use with CCDA1425-WM, CCDA1425-WMJ and CCDA1425-PM.



CCDA1425-FMSB

CCDA1425-FMSB Tinted/smoked bubble for CCDA1425-FM (V2GF1192-8BK)

Tinted/smoked bubble for exchange with the standard clear bubble that is delivered with the indoor ceiling flush mount CCDA1425-FM.



CCDA1425-SMSB

CCDA1425-SMSB Tinted/smoked bubble for CCDA1425-SM (V2GF1192-8BL)

Tinted/smoked bubble for exchange with the standard clear bubble that is delivered with the indoor ceiling surface mount CCDA1425-SM.



CCDA1425-WPHSB

**CCDA1425-WPHSB Tinted/smoked bubble for weatherproof housing
CCDA1425-WPH (V2GF1192-8BM)**

Tinted/smoked bubble for exchange with the standard clear bubble that is delivered with the weatherproof outdoor housing CCDA1425-WPH.



CCDA1425-VRHCB

**CCDA1425-VRHCB Clear bubble for weatherproof housing CCDA1425-VRH
(V2GF1192-8CC)**

Clear bubble for exchange with the standard bubble that is delivered with the weatherproof outdoor housing CCDA1425-VRH.



CCDA1425-VRHSB



CAPA2415-C230



CAPA2415-W230

CCDA1425-VRHSB Tinted/smoked bubble for weatherproof housing

CCDA1425-VRH (V2GF1192-8CB)

Tinted/smoked bubble for exchange with the standard bubble that is delivered with the weatherproof outdoor housing CCDA1425-VRH.

CAPA2415-C230 Indoor power supply unit (V2GF1800-8BK)

The power supply unit is used to connect loads that require 24 V AC operating voltage. The current consumption of a connected load must not exceed 2.5 A. The power supply unit is designed for connection to the 230 V AC / 50 Hz mains.

CAPA2415-W230 Outdoor power supply unit (V2GF1800-8BL)

The power supply unit is used to connect loads that require 24 V AC operating voltage. The current consumption of a connected load must not exceed 2.5 A. The power supply unit is designed for connection to the 230 V AC / 50 Hz mains. The enclosure with cable glands ensures ingress protection to IP 67.

Details for ordering

Type	Part No.	Designation	Weight
CCDA1425-WPH	V2GF1192-8BA	Weatherproof housing	4.0 kg
CCDA1425-VRH	V2GF1192-8CA	Vandal-proof weatherproof housing	4.0 kg
CCDA1425-SM	V2GF1192-8BB	Ceiling surface mount (indoor)	1.2 kg
CCDA1425-FM	V2GF1192-8BC	Ceiling flush mount (indoor)	1.4 kg
CCDA1425-WM	V2GF1192-8BE	Wall mount	3.4 kg
CCDA1425-WMI	V2GF1192-8BQ	Indoor wall mount	1.3 kg
CCDA1425-WMJ	V2GF1192-8BF	Wall mount with junction box	4.8 kg
CCDA1425-PM	V2GF1192-8BG	Pendant mount	3.0 kg
CCDA1425-PMI	V2GF1192-8BN	Indoor pendant mount adapter	0.63 kg
CCDA1425-PMA	V2GF1192-8BD	Pole mount adapter	0.8 kg
CCDA1425-CMA	V2GF1192-8BH	Corner mount adapter	1.0 kg
CCDA1425-EP	V2GF1192-8BJ	Extension pole	1.0 kg
CCDA1425-FMSB	V2GF1192-8BK	Tinted/smoked bubble for CCDA1425-FM	0.3 kg
CCDA1425-SMSB	V2GF1192-8BL	Tinted/smoked bubble for CCDA1425-SM	0.2 kg
CCDA1425-WPHSB	V2GF1192-8BM	Tinted/smoked bubble for CCDA1425-WPH	0.6 kg
CCDA1425-VRHCB	V2GF1192-8CC	Clear bubble for CCDA1425-VRH	0.6 kg
CCDA1425-VRHSB	V2GF1192-8CB	Tinted/smoked bubble for CCDA1425-VRH	0.6 kg
CAPA2415-C230	V2GF1800-8BK	Indoor power supply unit	1.9 kg
CAPA2415-W230	V2GF1800-8BL	Outdoor power supply unit	2.4 kg

Technical drawings

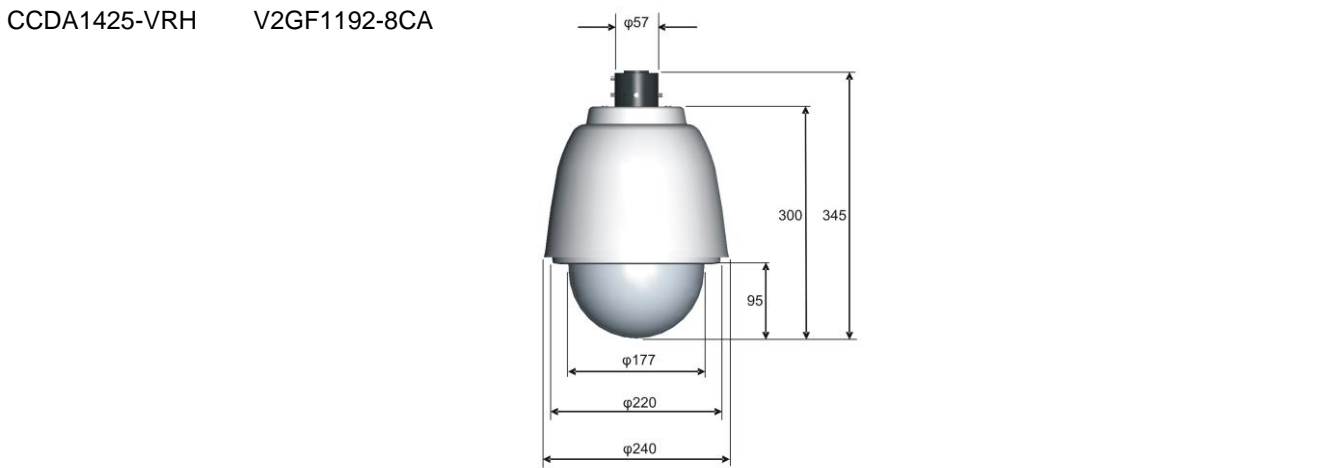
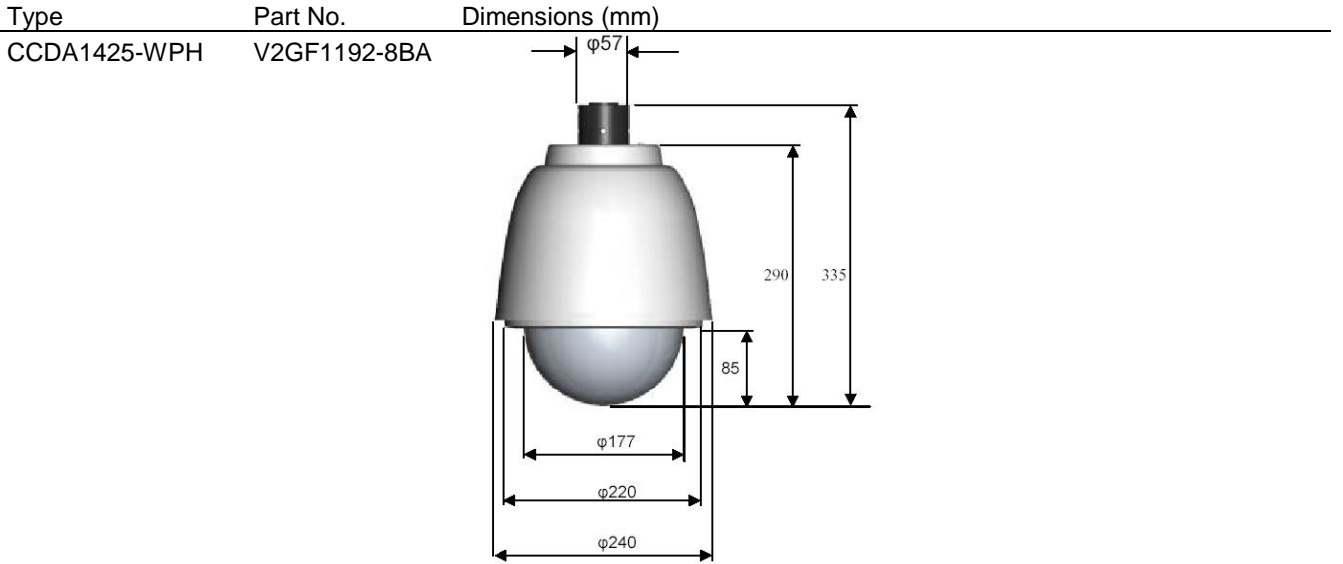

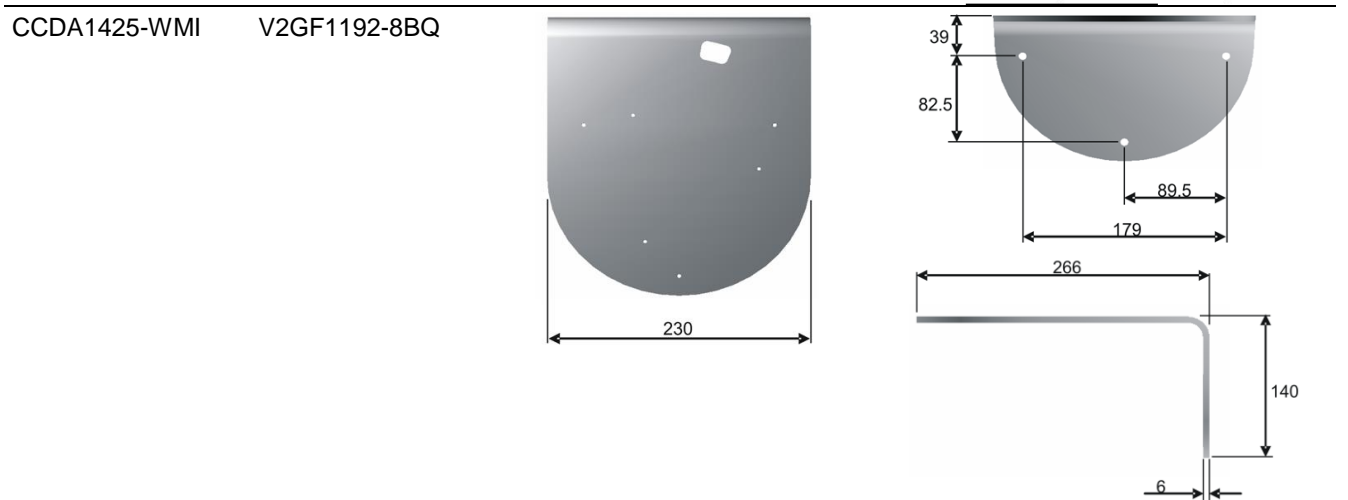
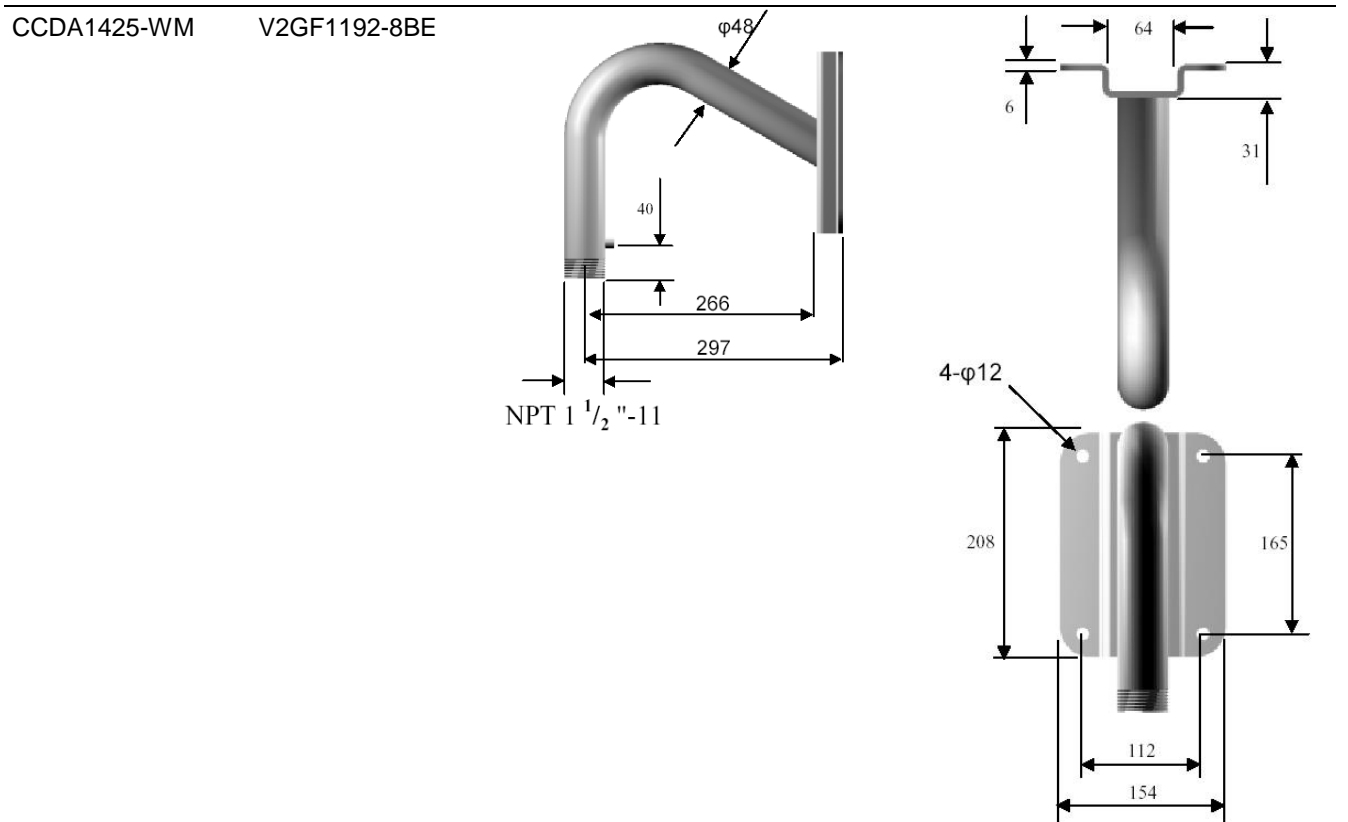
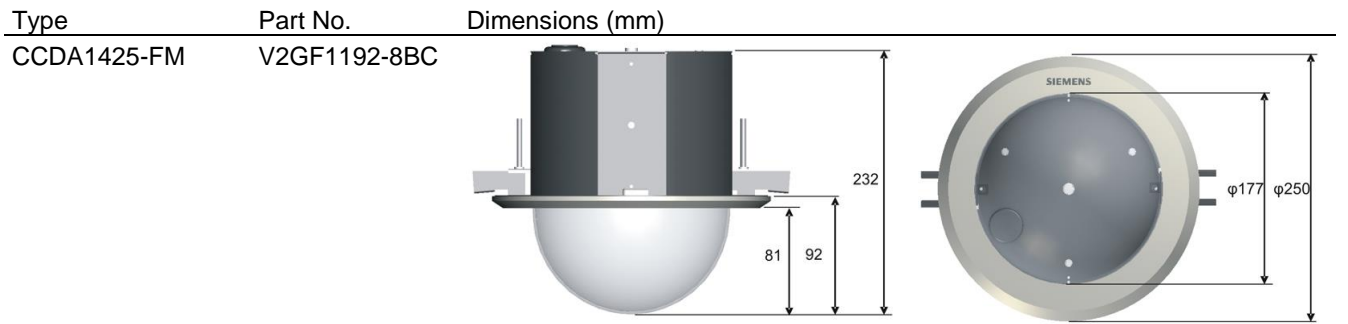

Type Part No. Dimensions (mm)

CCDA1425-WMJ V2GF1192-8BF

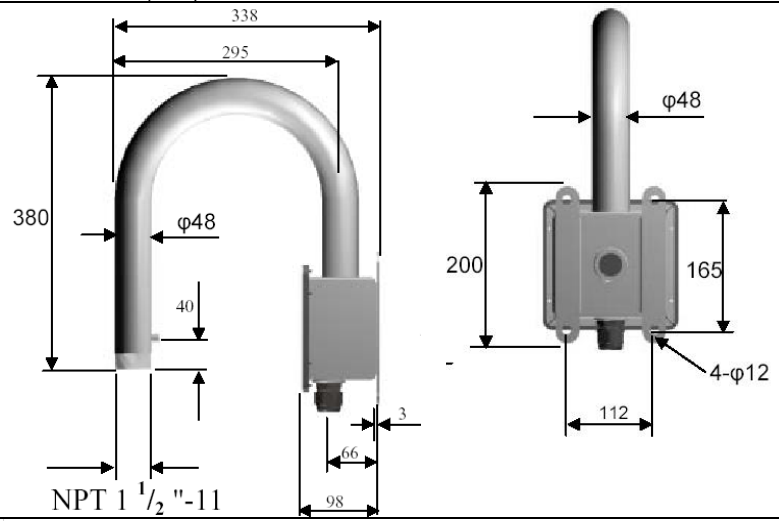

CCDA1425-PM V2GF1192-8BG

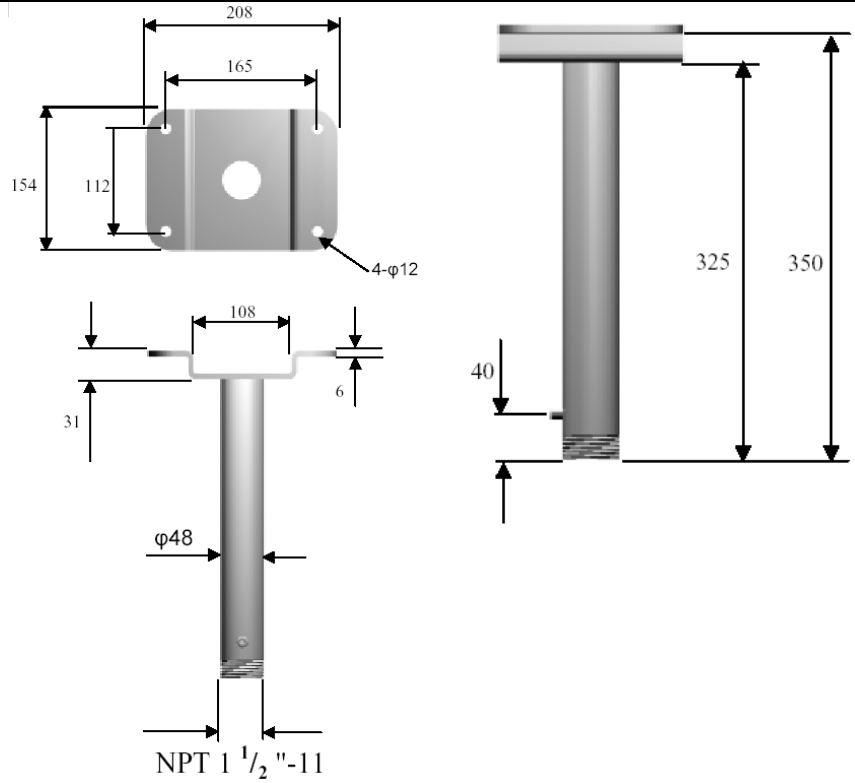

CCDA1425-PMI V2GF1192-8BN

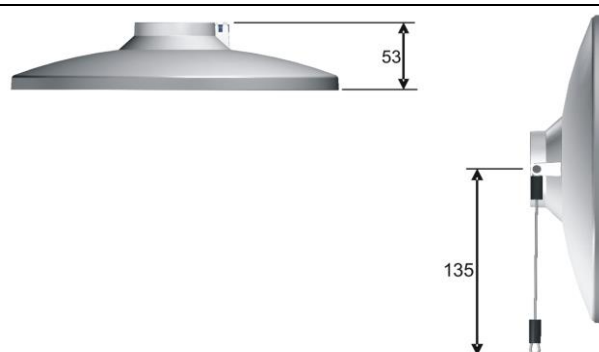

Type	Part No.	Dimensions (mm)
------	----------	-----------------

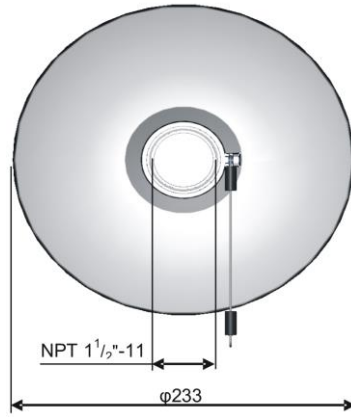

CCDA1425-PMA	V2GF1192-8BD	
--------------	--------------	--

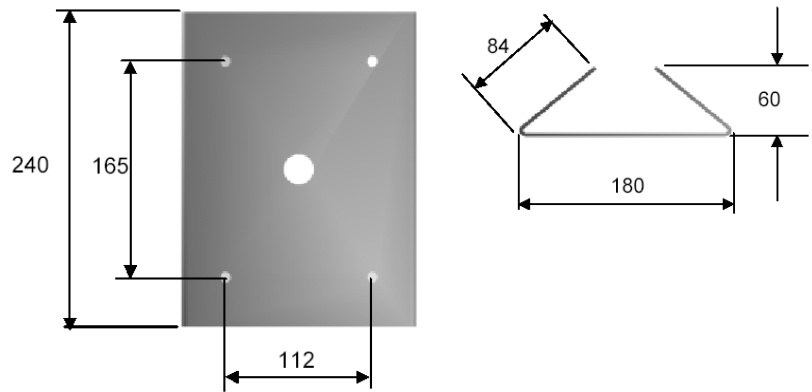

Type	Part No.	Dimensions (mm)
------	----------	-----------------

CCDA1425-CMA	V2GF1192-8BH	
--------------	--------------	--

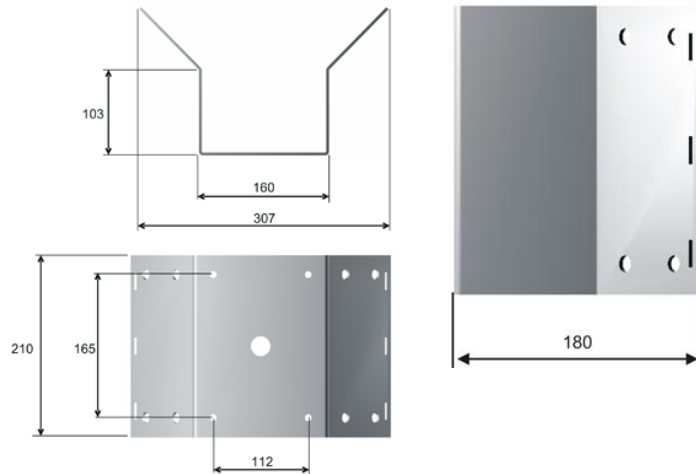

Type	Part No.	Dimensions (mm)
------	----------	-----------------

CCDA1425-EP	V2GF1192-8BJ	
-------------	--------------	--

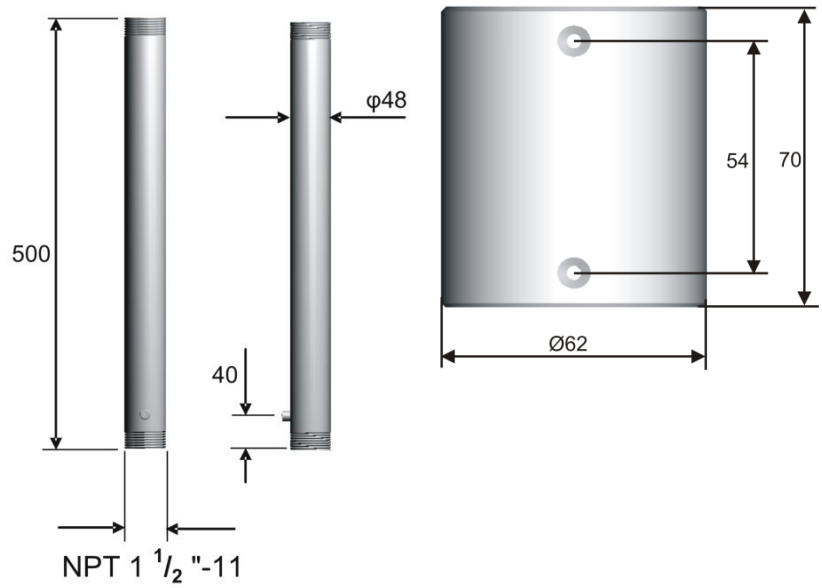

CCDA1425-FMSB	V2GF1192-8BK	
---------------	--------------	--

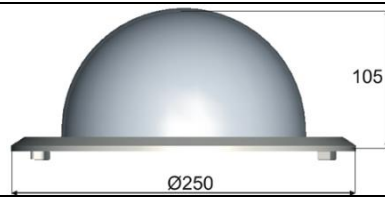

CCDA1425-SMSB	V2GF1192-8BL	
---------------	--------------	--

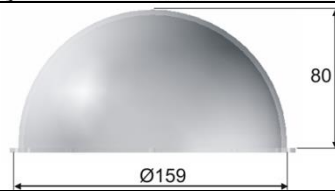

CCDA1425-WPHSB	V2GF1192-8BM	
CCDA1425-VRHCB	V2GF1192-8CC	
CCDA1425-VRHCB	V2GF1192-8CC	

