

SSC-FM561 / FM560

Analog Color Mini Dome Cameras

SONY
make.believe

700 TV Line Security Camera with Wide Dynamic Range

- Horizontal resolution of 700 TV lines (sharp mode)
- Wide dynamic range: 75 dB (typical)
- 3.7x variable focal lens
- Compact design
- Optical Day/Night function



KEY FEATURES

Wide Dynamic Range With DyanaViewSX Technology

The SSC-FM561 / FM560 incorporates DyanaViewSX technology to capture high-contrast scenes and produce clear images even under less-than-ideal lighting conditions. This means it can capture critical information that may have been missed by other cameras without such technology.

DyanaViewSX technology consists of three sub-technologies:

- **High-speed double shutter** provides a wider shutter speed range compared to previous technologies so that the cameras can reproduce images with incredibly wide dynamic ranges.
- **iBLC** compensates for the exposure levels in dark scenes to improve the visibility of the subject.
- **Advanced natural synthesizer** plays an important role in minimizing synthesized noise, which occurs when combining two images of different shutter speeds.

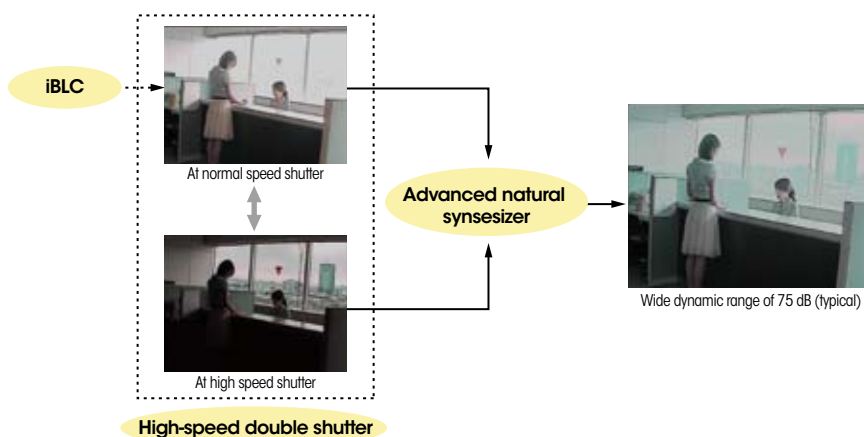

Superb Picture Quality With Accurate Color Reproduction

Employing a Super HAD II CCD sensor, the SSC-FM561 / FM560 offers a high horizontal resolution of 700 TV lines in sharp mode and produces amazingly clear and detailed images. Moreover, the cameras achieve a minimum illumination of 0.1 lx (F1.2, 50 IRE); therefore, the image quality under low-lighting conditions is great enough to enable round-the-clock security operations.

Noise Reduction

The SSC-FM561 / FM560 incorporates Adaptive DNR (Digital Noise Reduction) technology, which eliminates noise and motion blur to produce distinct and clear images. Adaptive DNR technology utilizes both an adaptive 2D filter and an adaptive 3D filter according to the AGC value to reduce noise.

New Three-hinge Structure

Easy and flexible camera angle adjustment can be achieved by a new three-hinge structure.



- a Panning
- b Tilting
- c Rotating

Optical Day/Night Function

The SSC-FM561/FM560 cameras offer an Optical Day/Night function to provide optimized sensitivity in both day and night shooting scenarios. As the scene illumination reduces and the acquired image darkens, the infrared filter is automatically removed and the camera switches to B&W mode, requiring only a minimum illumination of 0.01 lx (F1.2, 50 IRE). In addition, the Optical Day/Night function can be initiated on demand through an external control signal for added flexibility.

Wider Auto Tracing White Range (ATW)

The ATW function automatically adjusts the camera's white balance to adapt to sudden changes in lighting conditions. The SSC-FM561/FM560 provides an extremely wide ATW range of 2,000 K to 10,000 K, allowing adjustment-free operation under a variety of lighting conditions.

Back Light Compensation

Unwanted backlighting tends to cause the subject matter of an image to be cast into shadow. The BLC function of these cameras automatically compensates for such undesirable conditions and improves the visibility of the subject.

Other Features

- Custom Template (ENTRANCE, OFFICE, PARKING, SUBWAY, LOBBY, and STATION)
- User Presets
- Variable Gamma Curve
- Two Setting Modes
- DC servo Auto
- AC 24 V/DC 12 V operation
- Internal Lock/Line Lock
- Slow Shutter
- Digital Zoom

SPECIFICATIONS

	SSC-FM561	SSC-FM560
Camera		
Image device	1/3-type Super HAD CCD II	
Number of effective pixels (H x V)	570,000 pixels (976 x 582)	480,000 pixels (976 x 494)
Signal system	PAL standard	NTSC standard
Horizontal resolution	700 TV lines (sharp mode)	
S/N ratio	More than 55 dB (AGC Off)	
Minimum illumination	Color: 0.1 lx, B/W: 0.01 lx (F1.2, 50 IRE) Color: 0.06 lx, B/W: 0.006 lx (F1.2, 30 IRE)	
Dynamic range	75 dB (typical)	
Video output	VBS:1.0 Vp-p	
Synchronization	Internal/AC line lock selectable	
Gain control	Auto (OFF/Normal/Turbo)/Manual	
White balance	ATW/ATW-PRO/3200K/5600K/Manual	
Lens type	Built-in variable focal lens	
Zoom ratio	Optical 3.7x	
Horizontal viewing angle	101.8 ° to 27.4 °	
Focal length	f=2.8 to 10.5 mm	
F Number	F1.2 (Wide end), F2.6 (Tele end)	
Minimum object distance	300 mm (11 7/8 inches)	
Iris	Auto	
Panning range	355 degrees	
Tilting range	±77 degrees	
Swivel rotation	350 degrees	
Camera Features		
Day/Night	Yes (Optical D/N)	
Noise reduction	Yes (2DNR + 3DNR, Weak/Normal/Strong)	
Back light compensation	OFF/DynaViewSX/iBLC/SPOT	
Automatic tone reproduction	Yes (DynaViewSX mode only)	
General		
Mass	320 g (11.3 oz)	
Dimensions	ø121.6 x 86.5 mm (ø4 7/8 x 3 1/2 inches)	
Power requirement	AC 24 V ±10%, DC 12 V ±10%	
Power consumption	2.8 W	
Operating temperature	-10 °C to +50 °C (14 °F to 122 °F)	
Storage temperature	-40 °C to +60 °C (-40 °F to +140 °F)	
Operating humidity	20% to 80%	
Storage humidity	20% to 90%	
Supplied accessories	Operating instructions x1, Menu instructions x1, Template x1	
Optional accessories	YT-ICB140 In-ceiling Bracket	

DIMENSIONS

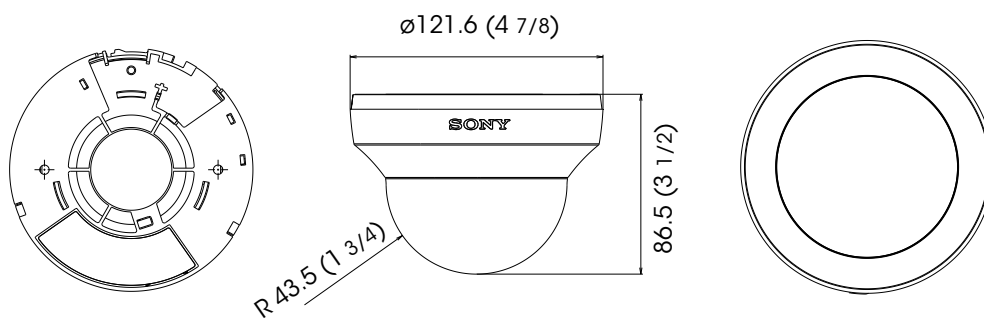

Unit: mm (inches)

Distributed by

© 2011 Sony Corporation. All rights reserved. Reproduction in whole or in part without written permission is prohibited. Features and specifications are subject to change without notice. The values for weight and dimension are approximate. "SONY", "make.believe", "Super HAD CCD II", and "DynaViewSX" are trademarks of Sony Corporation. All other trademarks are the property of their respective owners.