

L50DC4P

50mm F1.8 – CS-Mount

Compatible with 1/3" & 1/4" Cameras

- Focal Length:** 50mm
- Max. Relative Aperture:** 1:1.8
- Iris:** F1.8~Approx. F360
With ND Spot Filter
- Angular Field of View:** 1/3": 5.5° × 4.1°
1/4": 4.1° × 3.1°
- Min. Object Distance (M.O.D.):** 0.7m (From Front Vertex)
- Optical Back Focal Distance:** 19.71mm (In Air)
- Operation:** Focus: Manual
Iris: IG (Auto-Close System)
- Operation Voltage:** Close to Open: Less than 3V
Open to Close: More than 0.5V
- Operation Temperature:** -10 ~ +50°C (+14 ~ 122° F)
- Filter Size:** 43mm P0.75
- Mount:** CS-Mount
(Adjustable Lens Postion)
- Size, Approx. Weight:** 50.9 × 60 × 44.2mm (w/h/d), 125g
(Approx. 2.0 × 2.4 × 1.7in., 4.4oz.)

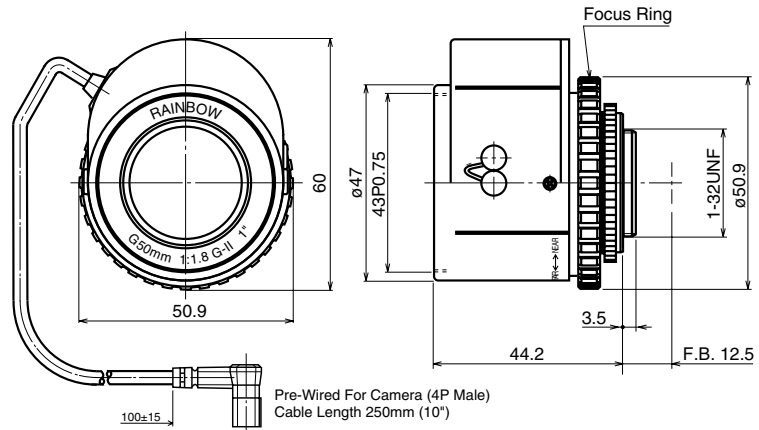

Camera Connector Wiring											
1 3	<table border="1"> <thead> <tr> <th>Pin</th> <th>Signal</th> </tr> </thead> <tbody> <tr> <td>1</td> <td>Brake – *</td> </tr> <tr> <td>2</td> <td>Brake + *</td> </tr> <tr> <td>3</td> <td>Drive +</td> </tr> <tr> <td>4</td> <td>Drive –</td> </tr> </tbody> </table>	Pin	Signal	1	Brake – *	2	Brake + *	3	Drive +	4	Drive –
Pin	Signal										
1	Brake – *										
2	Brake + *										
3	Drive +										
4	Drive –										
2 4											

* Also referred to as DAMP, CONTROL, or DUMP

L75DC4P

75mm F1.8 – CS-Mount

Compatible with 1/3" & 1/4" Cameras

- Focal Length:** 75mm
- Max. Relative Aperture:** 1:1.8
- Iris:** F1.8~Approx. F360
With ND Spot Filter
- Angular Field of View:** 1/3": 3.7° × 2.8°
1/4": 2.8° × 2.1°
- Min. Object Distance (M.O.D.):** 0.8m (From Front Vertex)
- Optical Back Focal Distance:** 21.85mm (In Air)
- Operation:** Focus: Manual
Iris: IG (Auto-Close System)
- Operation Voltage:** Close to Open: Less than 3V
Open to Close: More than 0.5V
- Operation Temperature:** -10 ~ +50°C (+14 ~ 122° F)
- Filter Size:** 46mm P0.75
- Mount:** CS-Mount
(Adjustable Lens Postion)
- Size, Approx. Weight:** 50.9 × 60 × 63.5mm (w/h/d), 200g
(Approx. 2.0 × 2.4 × 2.5in., 7.1oz.)

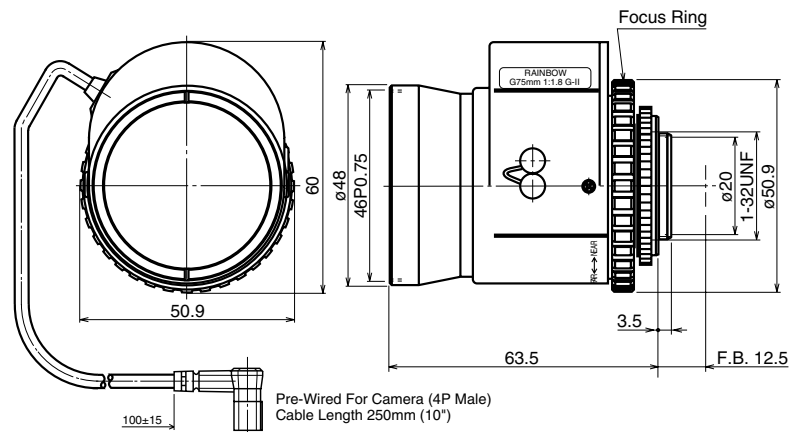

Camera Connector Wiring											
1 3	<table border="1"> <thead> <tr> <th>Pin</th> <th>Signal</th> </tr> </thead> <tbody> <tr> <td>1</td> <td>Brake – *</td> </tr> <tr> <td>2</td> <td>Brake + *</td> </tr> <tr> <td>3</td> <td>Drive +</td> </tr> <tr> <td>4</td> <td>Drive –</td> </tr> </tbody> </table>	Pin	Signal	1	Brake – *	2	Brake + *	3	Drive +	4	Drive –
Pin	Signal										
1	Brake – *										
2	Brake + *										
3	Drive +										
4	Drive –										
2 4											

* Also referred to as DAMP, CONTROL, or DUMP