

Manual Iris For Machine Vision

■ H1214-M(C61232)

C-MOUNT
Unit:mm

■ C1614-M(C31634)

C-MOUNT
Unit:mm

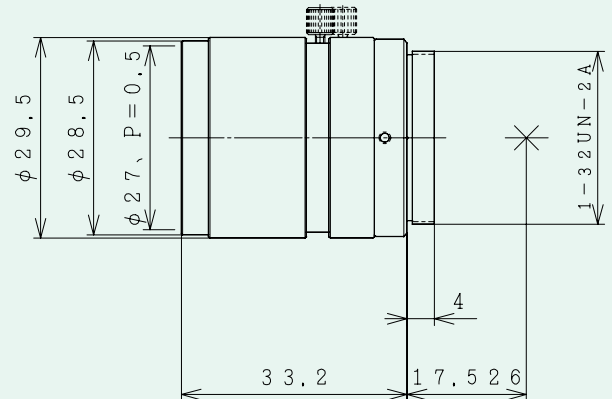
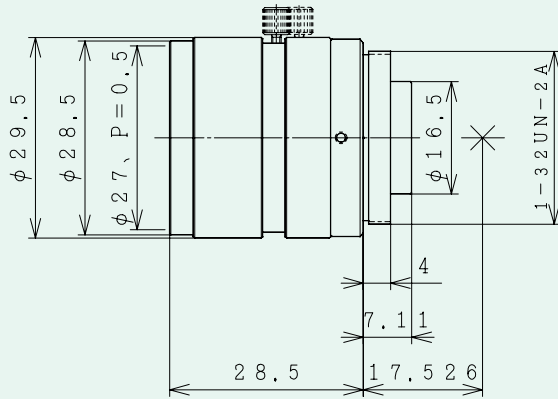

Manual Iris For Machine Vision

■ C2514-M(C32500)

C-MOUNT
Unit:mm

■ C5028-M(C35001)

C-MOUNT
Unit:mm

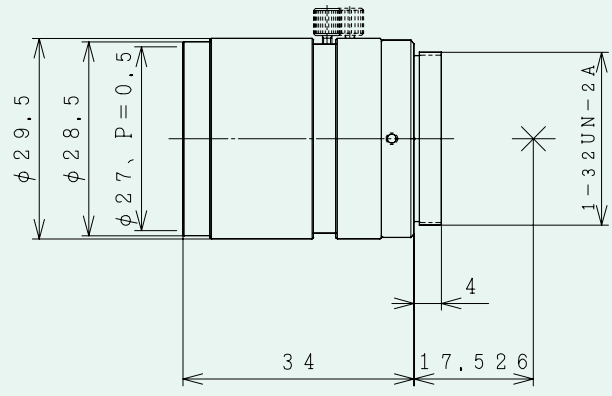
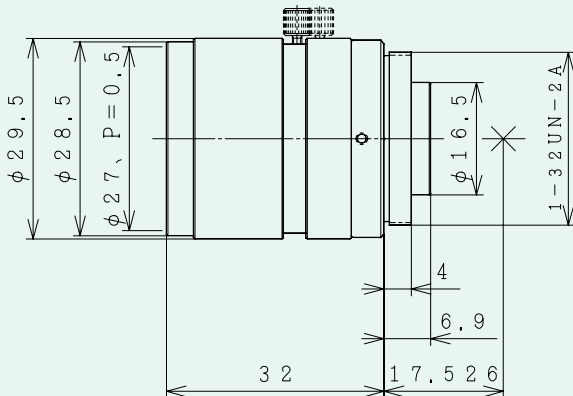

■ Specifications		H1214-M	C1614-M	C2514-M	C5028-M
Focal Length		12mm	16mm	25mm	50mm
Max. Aperture Ratio		1:1.4	1:1.4	1:1.4	1:2.8
Iris Range		F1.4~16	F1.4~16	F1.4~16	F2.8~22
Operation Method	Iris	Manual	Manual	Manual	Manual
	Focus	Manual	Manual	Manual	Manual
	Zoom	—	—	—	—
1/4 Format Angle of View	Horizontal	16.49	12.86	8.24	4.12
	Vertical	12.40	9.66	6.18	3.09
1/3 Format Angle of View	Horizontal	21.88	17.11	10.97	5.50
	Vertical	16.49	12.86	8.24	4.12
1/2 Format Angle of View	Horizontal	28.91	22.72	14.60	7.32
	Vertical	21.88	17.11	10.97	5.50
Min. Object Distance		0.25m	0.25m	0.25m	0.9m
Back Focal Length		11.50mm	14.61mm	11.50mm	21.03mm
Flange Back Length		17.526mm	17.526mm	17.526mm	17.526mm
Filter Screw Size		φ 27mm P=0.5mm	φ 27mm P=0.5mm	φ 27mm P=0.5mm	φ 27mm P=0.5mm
Temperature Range		-20°C~+50°C	-20°C~+50°C	-20°C~+50°C	-20°C~+50°C
Dimensions		φ 29.5×28.5mm	φ 29.5×33.2mm	φ 29.5×32mm	φ 29.5×34mm
Weight		55g	63g	55g	55g
Remarks		Lock Screw	Lock Screw	Lock Screw	Lock Screw