



PRODUCT SPECIFICATION

SD5TAC Series Spectra Lite™ Dome Systems

HIGH-PERFORMANCE INTEGRATED DOME SYSTEMS

CE



IP66

U.S. Patent
#5,931,432

Product Features

- High Resolution Camera
- In-ceiling and Pendant Models Available
- Auto Focus with Manual Override
- Programmable Camera Settings
- AC Line Lock
- 32 Presets
- Color (NTSC/PAL) Camera with 1 Lux Sensitivity
- Auto Iris with Manual Override
- 5.9-inch Acrylic Bubble
- Variable Scan Speed (.5-250°/Second)
- "Auto Flip" Dome Rotation
- 360° Continuous Pan Rotation
- Integral Multi-protocol Receiver/Driver
- Quick Disconnect Dome Drive
- Built-in Power Line Surge and Lightning Protection
- Easy to Install - Quick and Simple Electrical Connections
- Indoor/Outdoor Applications



IN-CEILING MODEL
SD5TAC-F0



ENVIRONMENTAL PENDANT
MODEL SD5TAC-PG-E0
(SHOWN WITH SWM-GY WALL MOUNT)

The **Spectra Lite™ Series** Surveillance Dome System is a lower cost alternative to Pelco's popular Spectra II Series Dome. The **Spectra Lite** features a high resolution, Integrated Optics Package (IOP) camera, full pan/tilt positioning mechanism and extensive receiver electronics. **Spectra Lite** is quick and easy to install and onscreen, user-friendly menus make it easy to program and operate.

All **Spectra Lite** models include a high-performance color CCD camera with a 16X zoom lens and auto focus capability.

The IOP camera is completely programmable with features such as backlight compensation, color balance, sharpness and iris level. The system is capable of 360 degree rotation and has an "Auto Flip" feature. Auto flip allows the dome to rotate 180 degrees and reposition itself for continuous viewing of any subject that passes directly beneath the dome. Other features include, high speed and variable speed capabilities (ranging from a 250 degrees per second pan motion to a slow speed of .5 degree per second), tilt positioning, preset positioning, and line lock.

The Integrated Dome System consists of a back box, dome drive, and lower dome. Components may be ordered as a complete system, or separately. This flexibility allows for future system upgrades. The **Spectra Lite** can be upgraded with the Spectra II® dome drive, giving the system all the programmable features of the Spectra II, excluding alarm and auxiliary features.

The **Spectra Lite** is available as either an in-ceiling or pendant mount model. The in-ceiling system may be installed in either suspended or hard ceilings. The pendant model mounts directly to any recommended mount, flush to a ceiling, or to 1.5-inch NPT female threaded pipe. All outdoor pendant models are environmentally sealed to a rating of IP66 and NEMA 4X and include a sun shield, heater and fan.

The **Spectra Lite** Dome System is available with an optional translator card that allows the dome to accept control commands from competitive control systems. These protocols add to the capability of the dome, which is also compatible with Pelco Coaxitron®, P protocol, and D protocol controls, including matrix switchers.



International Standards Organization Registered Firm ISO 9001 Quality System

TECHNICAL SPECIFICATIONS

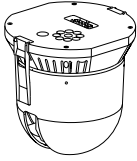

COMPONENT FEATURES

Dome Drive

- 32 Presets with 20-Character Labels Each
 - Rotating ABS Liner with Sealed Fixed Bubble ($\pm 0.5^\circ$ Preset Accuracy)
 - Variable Scan Speed – Scan speed can be programmable between 1-40 degrees per second
 - Pan Motion Profile Allows 80 Degree/Second Pan Speed (when not in Turbo mode)
 - Programmable Limit Stops for Auto/Random/Frame Scan Modes*
 - Coaxitron®, RS-422 “P” Series and “D” Series Protocols; Accepts Competitive Control Protocol with Optional Translator Card
 - Built-in Menu System for Setup of Camera Functions
 - “Auto Flip” Rotates Dome 180° at Bottom of Tilt Travel
- * Not available in CM7500 Matrix, MPT9000 or KBD9000 controls.

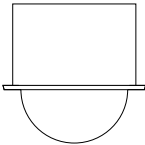

Back Box, In-Ceiling

- Single Back Box for Suspended or Hard Ceiling Applications
- Very Easy In-Ceiling Installation Requiring Only 5.25-inch Space Above Ceiling and 3.25-inches Below
- Minimum Ceiling Thickness .5-inch; Maximum 1.75-inches
- Quick Disconnect to Dome Drive
- Suitable for use in Environmental Air Handling Spaces
- Ratings: NEMA 1, IP40

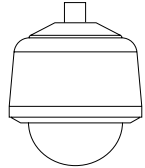

Back Box, Pendant

- Available in Black or Gray Finish
- Pendant 9.50-inch Overall Length x 8.52-inch Diameter (including dome)
- Quick Disconnect to Dome Drive
- Ratings: NEMA 4X, IP66

MECHANICAL

(DOME DRIVE ONLY)

Pan Movement	360° Continuous pan rotation
Vertical Tilt	Unobstructed +2° to -92°
Manual Pan/Tilt Speeds**	
Pan	0.5°–80°/sec manual operation, 150°/sec Turbo
Tilt	0.5°–40°/sec
Preset Speeds:	
Pan	250°/sec
Tilt	200°/sec

** For variable-speed operation an appropriate controller is required. (With non-variable speed control, Spectra Lite™ pan/tilt speed is 24°/second.)

ELECTRICAL

(Dome Drive Only)

Input Voltage	18-30 VAC; 24 VAC nominal
Input Power	30 vA nominal (indoor, w/o heater); 75 vA nominal (outdoor, with heater)
Fuse	1.6A

Cable Distances (24 VAC only)

	Wire Gauge					
	20	18	16	14	12	10
Indoor (30 vA)	94 ft (28m)	150 ft (45m)	238 ft (72m)	380 ft (115m)	603 ft (183m)	960 ft (292m)
Outdoor (75 vA)	37 ft (11m)	60 ft (18m)	95 ft (29m)	152 ft (46m)	241 ft (73m)	384 ft (117m)

GENERAL

Cable Entry (Back Box)		
In-ceiling	.75-inch conduit fitting	
Pendant	Through 1.5-inch NPT pendant mount	
Environment		
In-ceiling	Indoor only	
Pendant	Indoor/Outdoor	
Operating Temperature		
In-ceiling	32° to 122°F (0° to 50°C)	
Pendant		
Without heater:	32° to 140°F (0° to 60°C)	
	absolute maximum operating temperature; 32° to 122°F (0° to 50°C) sustained maximum operating temperature	
With heater:	(Assumes no wind chill factor; for detailed test conditions, contact Pelco.)	
Maximum	140°F (60°C) absolute maximum; 122°F (50°C) sustained maximum	
Minimum	-60°F (-51.11°C) absolute minimum;	
	Minimal icing at sustained minimum of -50°F (-45.56°C); Prevents icing at sustained minimum of -40°F (-40°C); de-ices .1 inch (2.5 mm) within 3 hours after power-up.	
Effective Projected Area (EPA*)	~175 square inches (<i>pendant only</i>)	
Dimensions	See dimension drawings	
Construction		
Dome Drive	Aluminum, ABS plastic	
Back Box	Aluminum	
Lower Dome	Acrylic	
Light Attenuation	Smoked (1/2 f-stop light loss)	
	Clear (Zero light loss)	
	Chrome (2 f-stop light loss)	
	Gold (2 f-stop light loss)	
Weight (approximate)	<u>Unit</u>	<u>Shipping</u>
Dome Drive	2.65 lb (1.20 kg)	5 lb (2.27 kg)
Back Box		
In-ceiling	1.5 lb (.68 kg)	2 lb (.9 kg)
Pendant Indoor	3 lb (1.36 kg)	4 lb (1.81 kg)
Pendant Outdoor	4.25 lb (1.93 kg)	6 lb (2.72 kg)
Lower Dome		
In-ceiling	.19 lb (.09 kg)	1 lb (.45 kg)
Pendant	1.3 lb (.59 kg)	2.2 lb (1.0 kg)

* Projects curved surfaces as flat to presume worst case conditions when calculating stress from external forces.

Reaction forces, attributable to environmental conditions, are minimal. Cyclic fatigue and stress corrosion, relative to the fastening of the dome/mount combination, must be closely monitored. Severity of environmental conditions dictates how often the fastening system should be checked. Thorough, scheduled maintenance procedures to monitor structural corrosion/fatigue is a requirement in any outdoor installation.

TECHNICAL SPECIFICATIONS

CAMERA/OPTICS

	Model DD5TAC	Model DD5TAC-X
Signal Format	NTSC	PAL
Scanning System	2:1 interlace	2:1 interlace
Image Sensor	1/4-inch interline transfer CCD	1/4-inch interline transfer CCD
Effective pixels	768 (H) x 494 (V)	752 (H) x 582 (V)
Horizontal Resolution	470 TV lines	460 TV lines
Lens	f1.6 (f = 3.9-63 mm optical, 16X optical zoom)	f1.6 (f = 3.9-63 mm optical, 16X optical zoom)
Horizontal Angle of View	45° at 3.9 mm wide zoom; 3° at 63 mm telephoto zoom	45° at 3.9 mm wide zoom; 3° at 63 mm telephoto zoom
Focus	Automatic with manual override and preset capability	Automatic with manual override and preset capability
Sensitivity	1 lux f1.6 at signal level of 40 IRE, gain high (AGC On)	1 lux f1.6 at signal level of 40 IRE, gain high (AGC On)
Sync System	AC line lock, phase adjustable via remote control*	AC line lock, phase adjustable via remote control*
White Balance	Automatic with manual override adjustable through on-screen programming*	Automatic with manual override adjustment through on-screen programming*
Shutter Speed	Automatic (electronic iris)/manual 1/60 - 1/10,000*	Automatic (electronic iris)/manual 1/50 - 1/10,000*
Iris Control	Automatic with manual override*	Automatic with manual override*
Gain Control	Automatic with manual override*	Automatic with manual override*
Signal to Noise Ratio	>46 dB	>46 dB

* Manual control of camera setup functions can be done with CM6700, CM6800, CM8500, CM9500, CM9740, CM9760 and MPT9500 controllers, but not with CM7500, MPT9000 or KBD9000 controllers.

CERTIFICATIONS/RATINGS

- ◆ CE (BB5T-F, BB5T-PB, BB5T-PG, BB5T-PG-E and DD5TAC-X)
- ◆ UL, cUL (models BB5T-F, BB5T-PB, BB5T-PG, BB5T-PG-E and DD5TAC)
- ◆ Suitable for use in environmental air handling spaces (BB5T-F)

Applicable directives/standards

- FCC
- NEMA Type 4X, IP66 (Pendant models)
- NEMA Type 1, IP40 (In-ceiling models)

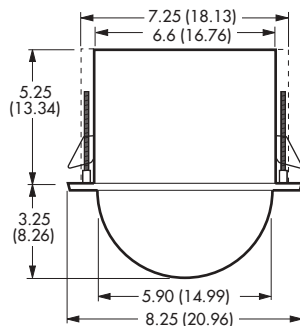

IN-CEILING DOME

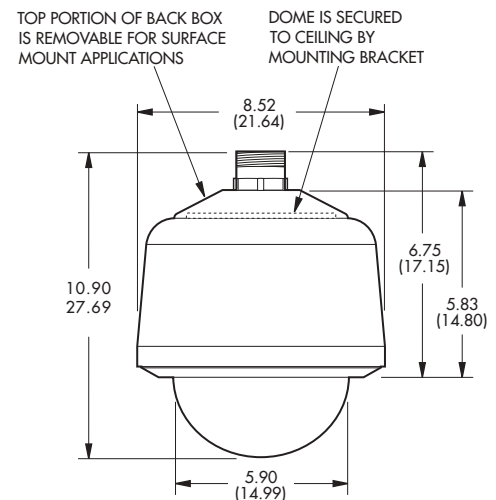

PENDANT DOME



SYSTEM MODELS AND RELATED PRODUCTS

Each Spectra Lite™ dome system consists of three components: Back Box (BB5T), Dome Drive (DD5) and Lower Dome (LD5). You can select from the system models listed below or order individual components. If ordering individual components, make sure you order one each back box, dome drive and lower dome.

SYSTEM MODEL NUMBERS

Lower Dome	Models*			
	In-Ceiling, Indoor	Pendant (Black) Indoor	Pendant (Gray) Indoor	Pendant (Gray) Environmental**
Smoked	SD5TAC-F0	SD5TAC-PB-0	SD5TAC-PG-0	SD5TAC-PG-E0
Clear	SD5TAC-F1	SD5TAC-PB-1	SD5TAC-PG-1	SD5TAC-PG-E1
Chrome	SD5TAC-F2	SD5TAC-PB-2	SD5TAC-PG-2	
Gold	SD5TAC-F3	SD5TAC-PB-3	SD5TAC-PG-3	

* For PAL and CCIR models add "-X" suffix to part number. (Example: SD5TAC-PG-E0-X)

** Environmental dome systems include heater and sun shield.

COMPONENT MODEL NUMBERS

Back Box		Dome Drive		Lower Dome	
BB5T-F	In-ceiling	DD5TAC	Color (NTSC) camera (128X)	LD5F-0	Smoked, in-ceiling
BB5T-PB	Pendant mount, black, indoor	DD5TAC-X	Color (PAL) camera (128X)	LD5F-1	Clear, in-ceiling
BB5T-PG	Pendant mount, gray, indoor	DD5-FM	Removable fixed mount bracket only (no camera package)	LD5F-2	Chrome, in-ceiling
BB5T-PG-E	Same as BB5A-PG except supplied with heater and sun shield, environmental			LD5F-3	Gold, in-ceiling
				LD5PB-0	Smoked, pendant, black
				LD5PB-1	Clear, pendant, black
				LD5PB-2	Chrome, pendant, black
				LD5PB-3	Gold, pendant, black
				LD5PG-0	Smoked, pendant, gray
				LD5PG-1	Clear, pendant, gray
				LD5PG-2	Chrome, pendant, gray
				LD5PG-3	Gold, pendant, gray
				LD5PG-E0	Same as LD5PG-0 except with heater
				LD5PG-E1	Same as LD5PG-1 except with heater

Notes:

To order a fixed mount dome system refer to the component models above and select one each of the following: back box (BB5T-F), dome drive (DD5-FM), plus choice of lower dome (LD5F-0, LD5F-1, LD5F-2 or LD5F-3).

For environmental applications, you must order the environmental back box (BB5T-PG-E) and lower dome (LD5PG-E0 or LD5PG-E1). (Heater kit is not sold separately and cannot be retrofitted.)

OPTIONAL ACCESSORIES

- BB5-PCA-BK Pendant conduit adapter, black
- BB5-PCA-GY Pendant conduit adapter, gray
- SCA1 Support rails for BB5A-F; for use in ceiling tile applications.
- TXB-AB Discontinued. Use TXB-AD or TXB-B translator board.
- TXB-AD Translator board for AD Manchester protocols.
- TXB-B Translator board for Philips (Burle) Allegiant Bi-phase protocols.
- TXB-V Translator board for Vicon® protocols.

RECOMMENDED POWER SUPPLIES

- MCS Series 24 VAC Indoor transformer (See C653 spec and C655 spec)
- WCS Series 24 VAC Weatherproof transformer (See C654 spec)

RECOMMENDED MOUNTS

In-Ceiling Domes

- SD5-P 2' x 2' drop ceiling panel, aluminum construction. Replaces 2' x 2' ceiling tile

Pendant Domes

- IWM Series Wall mount, with or without integral 24 VAC, 100 vA transformer. Black or gray finish. Can be adapted for corner, parapet or pole applications. (See C203 spec)
- MRCA Ceiling mount, black (See C234 spec)
- MRWA Wall mount, black (See C234 spec)
- PP4348 Parapet roof mount (See C204 spec)
- PP350/PP351 Parapet wall/roof mount (See C212 spec)
- SWM Series Compact wall mount, black or gray finish. Can be adapted for corner or pole applications. (See C293 spec)

Indicates change or addition since last revision.

Spectra Lite™ is a trademark of Pelco. Spectra II® and Coaxitron® are registered trademarks of Pelco. Specifications subject to change without notice. ©Copyright 2001, Pelco. All rights reserved.