



PRODUCT SPECIFICATION

EH5700 Series Enclosure OUTDOOR, LARGE



U.S. Patent
#307,915

Product Features

- All-Aluminum Construction
- Gas-Spring-Assisted Forward-Opening Lid
- Cable Entry Glands and Mounting Holes Located on Bottom of Enclosure
- Link-Lock Latches for Security
- Designed for Indoor/Outdoor Applications; For use with Fixed Mount or Pan/Tilt
- Special Options Include 120 VAC Outlet, Preset Lens Wiring Harness, and Window Wiper

The **EH5700 Series** are indoor/outdoor enclosures designed for use with Pelco's medium- and heavy-duty pan and tilts or fixed mounts. Constructed of aluminum and available in a 23-inch (58.42 cm) length (**EH5723**) and 29-inch (73.66 cm) length (**EH5729**), these enclosures are designed to accept 2/3-inch and 1-inch format cameras with either fixed focal length lenses or motorized zoom lenses.

The enclosure opens from the rear. The forward-opening lid allows for maximum accessibility during installation and when camera and lens adjustments are necessary. A gas spring securely holds the lid when fully opened. The lid is secured with side-mount link-lock latches. If desired, the latches can be secured with a padlock of suitable size for additional security.

All models feature an adjustable camera sled with a built-in elevation block that can be removed and inverted. The **EH5700 Series** enclosures are available with a full complement of accessories which include blower, heater, window defroster, sun shroud, window wiper, preset lens wiring harness, 120 VAC outlet, and thermal insulation.

The **EH5700 Series** can be used in fixed mount applications or mounted to a PT680 Series medium duty pan/tilt or PT1250 Series heavy duty pan/tilt.



EH5723



ENCLOSURE WITH SUN SHROUD

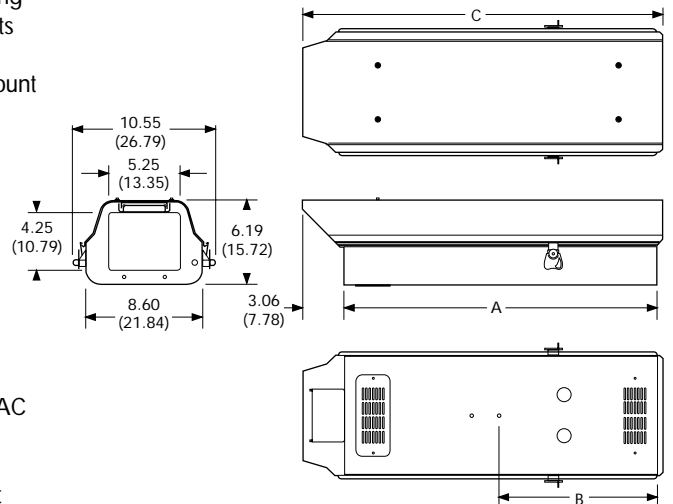

MODEL	A	B	C
EH5723	23.00 (58.42)	11.50 (29.21)	26.50 (67.31)
EH5729	29.00 (73.66)	14.50 (36.83)	32.50 (82.55)

NOTE: VALUES IN PARENTHESES ARE CENTIMETERS; ALL OTHERS ARE IN INCHES.

ENCLOSURES

OUTDOOR



International Standards Organization Registered Firm ISO 9001 Quality System



TECHNICAL SPECIFICATIONS

MODELS

Model Number	Basic Enclosure	120 VAC	24 VAC	230 VAC	Heater	Defroster	Blower	Max. Power Consumption*
EH5723	•							
EH5723-1		•			•			105W
EH5723-2			•		•			60W
EH5723-3				•	•			85W
EH5729	•							
EH5729-1		•			•			105W
EH5729-2			•		•			60W
EH5729-3				•	•			85W

*If optional defroster is used, add 15W to consumption

ELECTRICAL

Input Voltage 24, 120 or 230 VAC, 50/60 Hz
 Electrical Connection Connectors for power input, lens, camera and accessories (-1/-2/-3 models only)
 (-1/-2/-3 models only) Heater and defroster activate ON at 42-58°F (6-14°C) and OFF at 72-88°F (22-31°C).
 Blower activates ON at 77-93°F (25-34°C) and OFF at 62-78°F (17-26°C)

MECHANICAL

Camera Mounting Removable camera sled; can be inverted
 Cable Entry Two PG13.5 UL glands on bottom of enclosure; 0.47-inch (1.19 cm) maximum cable diameter
 Cable Entry Holes .875-inch (2.22 cm) diameter; will accept 0.5-inch (1.27 cm) conduit fitting when compression gland is removed
 Connectors Video BNC
 Camera Sync BNC
 Latches Link-lock No. 3, stainless steel; can be secured with padlocks (not supplied)
 EH5723 Series (2), EH5729 Series (4)

GENERAL

Max. Camera and Lens Dimensions EH5723 Accepts camera & lens combinations (including BNC connector) up to: 22" L x 7.5" W x 5.5" H (55.88 x 19.05 x 13.97 cm)
 EH5723-1/-2/-3 15.5" L x 6.25" W x 5.5" H (39.37 x 15.88 x 13.97 cm)
 EH5729 28" L x 7.5" W x 5.5" H (71.12 x 19.05 x 13.97 cm)
 EH5729-1/-2/-3 21.5" L x 6.25" W x 5.5" H (54.61 x 15.88 x 13.97 cm)
 Viewing Window Glass, 0.25-inch (6.35 mm) thick
 4.25" H x 5.25" W (10.79 x 13.33 cm)
 Construction Aluminum, 0.080-inch (.20 cm) thick (body and lid)
 Finish Gray polyester powder coat
 Environment Indoor/Outdoor;
 -10° to 120°F (-23° to 49°C)

Indicates change or addition since last revision.

Weight	Unit	Shipping
EH5723	11 lb (4.98 kg)	12 lb (5.43 kg)
EH5723-1,-2,-3	13 lb (5.88 kg)	15 lb (6.79 kg)
EH5729	16 lb (7.24 kg)	18 lb (8.15 kg)
EH5729-1,-2,-3	18 lb (8.15 kg)	20 lb (9.06 kg)

CERTIFICATIONS/RATINGS

- ◆ CE compliant (models EH5723/-2/-3 and EH5729/-2/-3)
- ◆ UL listed to Standard 2044 (except 230 VAC models)
- ◆ cUL listed to Standard CSA22.2 (except 230 VAC models)
- ◆ NEMA Rating: 3R (4 when block-off plates are used)

OPTIONAL ACCESSORIES

- BK57-1 ◆ Blower kit, 120V, 15W
 - BK57-2 ◆ Blower kit, 24V, 10W
 - BK57-3 ◆ Blower kit, 230V, 15W
 - HK57-1 ◆ Heater kit, 120V, 90W
 - HK57-2 ◆ Heater kit, 24V, 50W
 - HK57-3 ◆ Heater kit, 230V, 70W
 - O/I-PCB Accessory interface board; thermostatically controls heater, blower, and defroster operation (one per enclosure required)
 Preset position lens wire harness
 - O/I-LPP ◆ 120 VAC electrical convenience outlet
 - O/I-OUTLET ◆ Sun shroud for EH5723 series enclosures
 - SS5723 Sun shroud for EH5729 series enclosures
 - SS5729 Thermal insulation, EH5723/EH5729 series
 - TI57
 - WD57-1 ◆ Window defroster, 120V, 30W
 - WD57-2 ◆ Window defroster, 24V, 30W
 - WD57-3 ◆ Window defroster, 230V, 30W
 - WW5723-1 ◆** Window wiper, EH5723 series, 120V, 15W
 - WW5723-2 ◆** Window wiper, EH5723 series, 24V, 15W
 - WW5723-3 ◆** Window wiper, EH5723 series, 230V, 15W
 - WW5729-1 ◆** Window wiper, EH5729 series, 120V, 15W
 - WW5729-2 ◆** Window wiper, EH5729 series, 24V, 15W
 - WW5729-3 ◆** Window wiper, EH5729 series, 230V, 15W
- ◆ These accessories are factory wired with a plug-in connector for use with the O/I-PCB. The O/I-PCB is included with all -1/-2/-3 models. You must order one O/I-PCB if you are using a basic enclosure (EH5723 or EH5729) with these optional accessories.

*Factory installed option only; consult factory for availability.

RECOMMENDED MOUNTS

(refer to Enclosure and Mount Cross-Reference for a complete list)

Pedestal

MM22 Medium duty pedestal mount. Max. load 40 lb (18.12 kg). (See C227 spec)
 PM2000, Pedestal mount. Max. load 125 lb (56.62 kg)
 PM2010** (See C255 spec)

Wall

EM22 Medium duty wall mount. Max. load 40 lb (18.12 kg). (See C227 spec)
 WM2000** Wall mount. Max. load 75 lb (33.97 kg)
 (See C266 spec)

Adapter

AH2000 Adjustable head. (See C255/C266 spec)

**Use with AH2000 adjustable head

RECOMMENDED PAN/TILTS

PT680 Series Medium duty pan/tilt, 24 VAC. Max. load 50 lb (22.7 kg) (See C337 spec)
 PT1250 Series Heavy duty pan/tilt, 120V or 230V. Max. load 100 lb (45.4 kg) (See C370 spec)

Specifications subject to change without notice.
 ©Copyright 2000, Pelco. All rights reserved.

ENCLOSURES
OUTDOOR