



SCB 282PRO ICR day/night high resolution camera

fog penetration, 600 TV lines resolution

3D noise reduction

scheduled ICR day/night switching

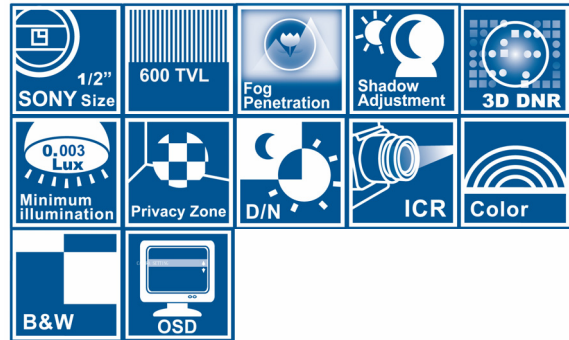

The SCB282PRO features a SONY 1/2" Exview Hi-Res CCD and exceptional fog penetration capabilities. It is a brilliant next-generation CCTV solution that delivers outstanding surveillance performance.

The SCB282PRO features industry-leading fog penetration technology that enables it to recover real color images from foggy or smoky video streams. It is the perfect solution for demanding environments plagued by fog, pollution, or even sand storms. Scheduled ICR day/night switching enables users to schedule times at which the camera switches from day mode to night mode, and vice versa, ensuring that the camera captures images in the correct mode. The SCB282PRO is also equipped with 3DNR functionality, allowing it reduce image noise and produce exceptionally clear images in low-light conditions.

Fog Penetration

The SCB282PRO's fog penetration technology peers through fog and smoke to recover real color images from foggy or smoky video streams, enhancing the camera's identification ratio by delivering more information-rich imagery.

Scheduled ICR Day/Night Switching

Users can schedule automatic switches between color and b/w modes. When subjected to transitory external lighting changes, sensor-based switches can inadvertently change modes, causing cameras to capture b/w images in daylight and color images at night. Scheduled switching ensures that the camera remains unaffected by such external factors and continues to capture images in the correct mode.

Shadow Adjustment

The shadow adjustment function adjusts exposure levels in shadowed portions of images to make dark areas more visible while retaining detail in bright areas.

3D DNR

3D noise reduction is a powerful method for reducing image noise that produces extremely clear images even in very dim lighting conditions.

2009.12.10 version.

MESSOA reserves the right to update this datasheet at any time without notice.

MESSOA USA e-mail:info.us@messo.com//MESSOA Taiwan e-mail:info@messo.com



Specifications

Signal system	NTSC	PAL	
Image system			
Imaging area	6.5mm x 4.9mm		
Image pickup device	SONY 1/2" Exview Hi-Res CCD		
Effective pixels(HxV)	768 x 494	752 x 582	
Electric			
Scanning system	2:1 Interlace V: 59.94Hz,	2:1 Interlace V: 50Hz,	
	H: 15.734KHz	H: 15.625KHz	
Sync system	Internal / linelock		
Horizontal resolution	600/ 700 TV lines (day/night mode)		
Lens mount	CS with easy backfocus		
Gamma correction	10 levels selectable		
Minimum illumination	Day mode: 0.01 lux(F1.4, AGC on, 10 IRE); 0.04 lux(F1.4, AGC on, 50 IRE)		
	Night mode: 0.003 lux(F1.4, AGC on, 10 IRE); 0.01 lux(F1.4, AGC on, 50 IRE)		
S/N ratio	More than 50dB (AGC off)		
Iris control	Video / DC driver		
Lumii	9 levels selectable		
White balance	ATW1 / ATW2 / Manual		
Electric shutter	Auto (1/60 to 1/100K sec.)/ Manual 46 steps (1/60 to 1/100K sec.)	Auto (1/50 to 1/100K sec.)/ Manual 46 steps (1/50 to 1/100K sec.)	
BLC	BLC1/ BLC2/ BLC3 BLC4/ BLC5/ BLC6/ Off		
DNR	Off/ 2DNR/ 3DNR		
Privacy zone	On/ Off, up to 8 zones		
Day/Night mode	Auto/ Mono/ Color/ D/N Sync/ Schedule		
OSD	Yes		
Fog Penetration	6 levels selectable		
Shadow Adjustment	On/ Off		
Mirror	On/ Off		
Flickerless	Yes		
Chroma	9 levels selectable		
Aperture control	High/ Mid/ Low		
Remote control	Yes (RS485)		
Video output	1Vpp composite output 75 ohm		
Power supply			
Power requirement	—	DC12V/ AC24V	AC90 ~ 260V
Power consumption	10W (max.)		
Environment			
Operating temperature	-10°C ~ 50°C		
Operating humidity	30% ~ 90% RH		
Storage temperature	-20°C ~ 60°C		
Mechanism			
Dimensions(WxHxD)	66mm x 55mm x 130mm		
	(2.6" x 2.16" x 5.11")		
Weight	500g (1.10 lb.)		
Ordering information	—	SCB282PRO-HP5	SCB282PRO-HP7

2009.12.10 version.

MESSOA reserves the right to update this datasheet at any time without notice.

MESSOA USA e-mail:info.us@messo.com/MESSOA Taiwan e-mail:info@messo.com

Dimensions

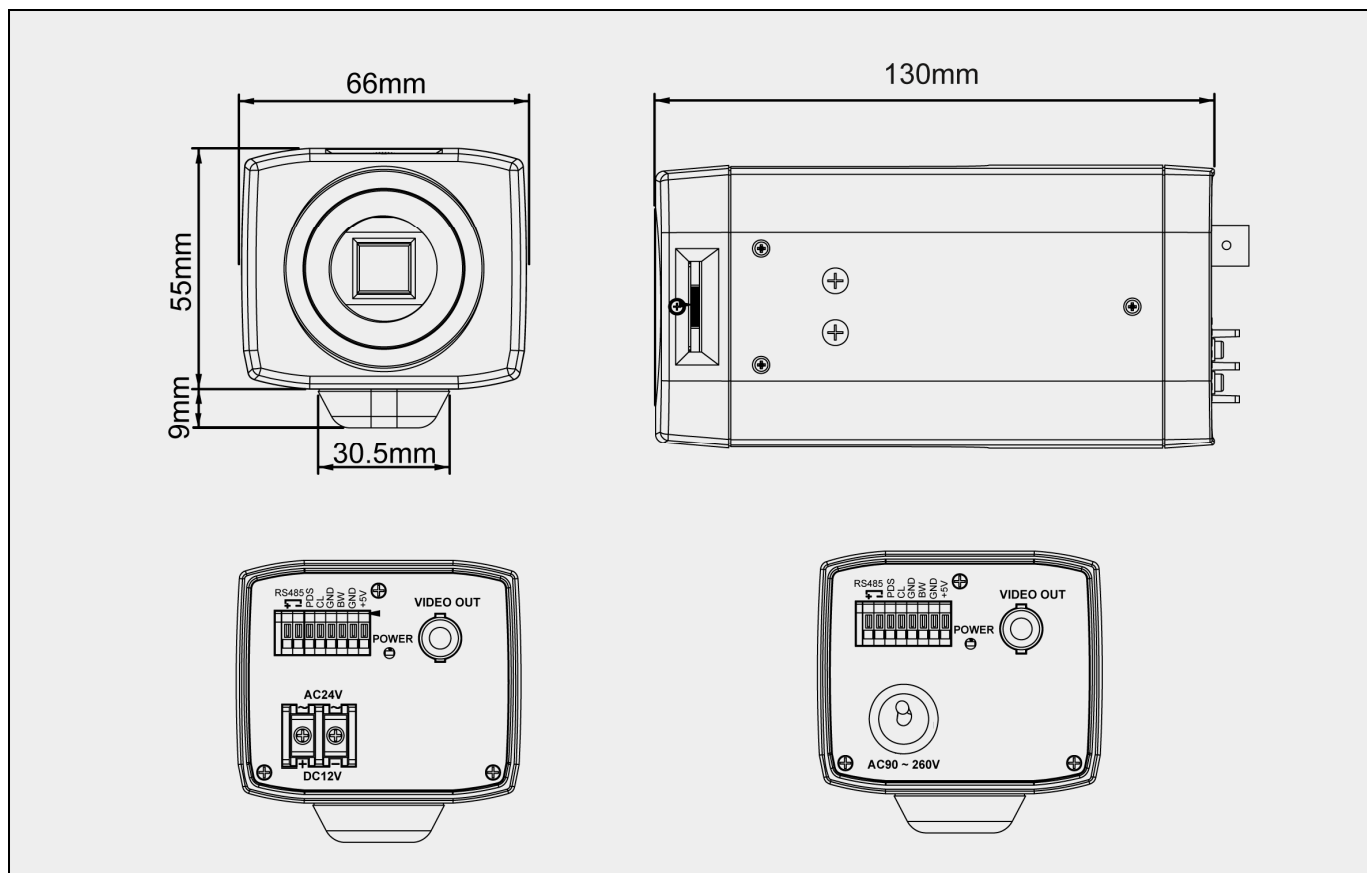

2009.12.10 version.

MESSOA reserves the right to update this datasheet at any time without notice.

MESSOA USA e-mail: info.us@messo.com / MESSOA Taiwan e-mail: info@messo.com