

## HRSD40F SERIES

### 4 CHANNEL EMBEDDED DIGITAL VIDEO RECORDER

The HRSD40F Series digital video recorder (DVR) combines the benefits of digital recording with the advanced processing of a multiplexer. The HRSD DVRs feature Honeywell's sophisticated, proprietary XtraStor compression technology that provides more storage on smaller media without sacrificing image quality – resulting in days, weeks and even months of high-resolution video storage.

Recording at a rate of up to 120/100 ips NTSC/PAL, HRSD supports configurable ips per camera and other high-end recording capabilities to efficiently capture and provide long-term storage of video, text, and audio. Multiple search engines enable the user to quickly find the video evidence. Transfer of video evidence is fast and easy using the clip-copy function which allows video, audio, and text evidence to be burned onto a USB stick via the DVR's front panel USB port. A viewer executable is included with each clip, which eliminates the need to install a viewer separately to the evidence viewing PC. This maximises ease-of-use for anyone who needs to view the evidence after the occurrence of a fraudulent event.

The same powerful Remote Administration System Plus (RASplus) software used with HRXD is also used by HRSD. The RASplus advanced feature set includes simultaneous connection of up to 16 sites over a digital network. Users can configure and download software updates to remote DVRs from a central site, saving time and money by eliminating the need for many site visits.

### Market Opportunities

When combined with an external interface/filter device such as SmartPIT™, the HRSD Series offers a powerful evidence reporting mechanism for retail and financial applications by recording POS and ATM transaction text data in addition to audio and video.

For surveillance systems integrating multiple devices that need to share a single time reference, SNTP allows the HRSD's time clock to be synchronised to an external time reference.

### Features:

- 4 looping video inputs
- Continues recording while transmitting to remote site and during playback
- Records up to 120/100 images per second (NTSC/PAL)
- Front panel USB port
- IR remote control
- Text input for interface to automated teller machines (ATM) and point-of-sale (POS) terminals
- Time synchronisation between DVR and time server or other DVR
- PTZ dome control for a wide variety of protocols
- Network 10/100BaseT (Remote Access Software RASplus included)
- Multiple search engines (date/time, calendar, event, text-in)
- Multiple recording modes (time-lapse, pre-event, alarm, motion and panic)
- WebGuard remote access via PC with Microsoft® Internet Explorer web browser
- Linux OS — OS embedded in flash



## HRSD40F SERIES

### SPECIFICATIONS

RAS Plus Software	
Sessions Maximum per HRSD40F recorder	14 simultaneous connections
Administration	2 sessions
Users Viewing Live Video (and activating outputs)	10 sessions
Users Retrieving Video	2 sessions
Compatibility	Microsoft Windows XP or Vista; see RASplus User Guide for additional detail. Doc. 900.0857
Recorder Unit	
Video Standard	NTSC or PAL (Auto Detect)
Video Display Format	720 x 480 (NTSC) 720 x 576 (PAL)
Recording and Transmission Compression Algorithm	XtraStor compression technology
Record Mode	(FIFO) Continuous buffer
Recording Capacity	Hard drive 250 GB
Recording Rate (Global)	Up to 100 ips (PAL)
Video Resolution Settings	CIF: 352 x 288 (PAL) 2CIF: 704 x 288 (PAL) 4CIF: 704 x 576 (PAL)
Video Motion Detection	Configurable zone detection area and sensitivity
POS/ATM serial	RS232 port accepts a single data stream or up to four multiplexed data streams using VP filter
Event Recording and Reporting	Input via – alarm i/p contacts, motion and POS/ATM data. Reporting via internal buzzer, alarm o/p contacts, RAS(plus) and e-mail notification
Removable Media	Via front panel USB 2.0 port
Still Image	Bitmap or JPEG file format using RASplus
Front Panel Control	Intuitive operation using front panel controls or IR remote
SNTP Client	Synchronise timing to SNTP server
DHCP Enabled	DHCP or manual IP entry and ADSL with PPPoE
Port number set-up	Individual entries for remote admin, remote watch, remote search, remote callback
PTZ Protocols Support	Support for up to 50 PTZ protocols
Language Support	English, French, Spanish, Dutch, Italian and Portuguese
Internal Buzzer	Selectable upon alarm or event

Connections	
Video Input	4 – Looping, BNC 1.0 Vp-p @ 75 Ohms, Auto Terminating
Video Output	1 – Composite BNC 1.0 Vp-p @ 75 Ohms 1 – VGA alternative to using BNC
Audio Input/Output	4 – Line level, RCA 1 – Line Out, RCA
Alarm/Control Inputs General Purpose	4 - TTL programmable as NC or NO, 4.3V threshold
Alarm Reset Input	1 TTL terminal block
Control Outputs	1 relay output, terminal block, NC or NO, 2 A @ 125 VAC, 1 A @ 30 VDC
Serial Ports	1 – RS232-C DB9 (P), 1 – RS485 port
Primary Storage	Internal HDD
Networking	10/100 base Ethernet (RJ-45)
IR Port	IR remote control
Electrical	
Input Voltage	100 – 240 VAC, 0.6 A, 60 – 50 Hz, Autosensing
Power Consumption	30 Watts
Mechanical	
Dimensions (W x H x D)	340 mm x 46.5 mm x 310 mm
Weight	Unit: 3.0kg Shipping: 4.5kg
Construction	Housing: Steel chassis Finish: Black matt paint
Environmental	
Temperature	Operating: 5°C to 40°C Storage: 0°C to 60°C
Relative Humidity	0% - 90%, non-condensing
Regulatory	
Emissions	FCC: Part 15 Subpart B, Class A CE: EN55022:2006 Class A EN61000-3-2:2006 EN61000-3-3:1995+A1:2001+A2:2005
Immunity	CE: EN50130-4:1995 + A1:1998 + A2:2003
Safety U.S. and Canada International	UL: 60950, First Edition (2003), CSA C22.2 No. 60950-1-03 First Edition April 1, 2003 CE: IEC60950-1:2001 (First Edition) and/or EN60950-1:2001 + A11:2004

## HRSD40F SERIES

### SYSTEM DRAWING

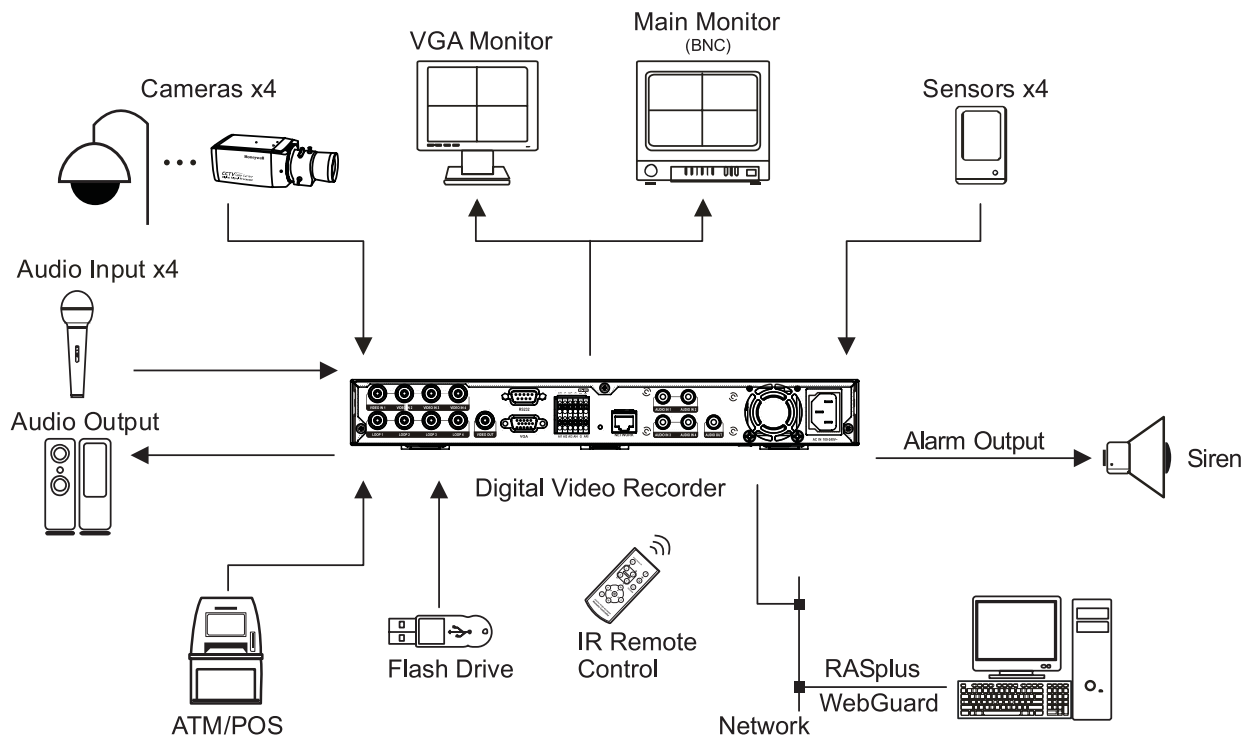

# HRSD40F SERIES

## ACCESSORIES, DIMENSIONS, ORDERING

Accessories Included	
HRSD40RC	Spare IR Remote Controller
Recommended Accessories	
POS/ATM Interface	
HASMPIT	SmartPIT®, POS/ECR or ATM text inserter
Monitors	
HMLCD19e2X	19" e-Series Colour LCD Monitor (VGA)
HMLCD17LX	17" L-Series Colour LCD monitor (VGA)

Recommended Accessories, cont.	
Cameras	
HCU484X	Ultra-wide dynamic high resolution body camera
HD3CHX	Super high resolution 3" mini-dome camera
HD4DX	Super high resolution day/night vandal resistant mini-dome camera
ACUIX™	High-performance PTZ camera
Surge Protection	
HCSP1	Camera surge protector
HDSP1	PTZ dome surge protector

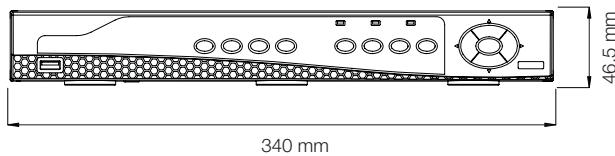

**Front View**

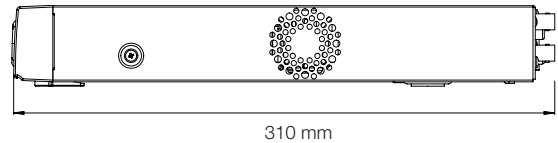

**Side View**

Ordering	
HRSD40F250X	4 channels video, 4/1 audio in/out, 250 GB hard drive, USB, PAL

**NOTE:** Honeywell reserves the right, without notification, to make changes in product design or specifications.

### For additional information,

please visit [www.honeywell.com/security/uk](http://www.honeywell.com/security/uk)

### Honeywell Security & Data Collection

Honeywell Systems Group  
Aston Fields Road  
Whitehouse Industrial Estate  
Runcorn  
Cheshire  
WA7 3DL

Tel: 08448 000 235  
[www.honeywell.com](http://www.honeywell.com)

HVS-HRSD4-02-EN(0909)DS-GCSC  
September 2009  
© 2009 Honeywell International Inc.

# Honeywell