

HD50PX

600 TVL FIXED LENS VANDAL MINI-DOME CAMERA

The Honeywell Performance Series includes a variety of indoor, outdoor and low light cameras for virtually any installation. Ideal for a diverse range of applications, the Performance Series includes a wide range of high performing IR bullet cameras and mini-domes that are easy to install and even easier to use.

The HD50PX is a rugged indoor/outdoor fixed mini-dome camera. The high-impact dome housing is vandal resistant and weather tight. The integrated housing protects the camera from dust, dirt and water as well as physical harm from strong external impacts. The visually appealing low profile design blends with its surroundings, making the HD50PX the obvious choice for architecturally sensitive installations. The HD50PX incorporates a 1/3" CCD that offers 600 TV lines of crisp, clear horizontal resolution. The camera comes equipped with a built-in fixed lens (f=3.8 mm) and a 3-D axis gimbal that is capable of 360° of pan, 180° of tilt and 360° of horizontal rotation.

The HD50PX installs quickly and easily. It comes standard with a two-conductor pigtail that connects to the barrel connector so there is no need to cut wires during installation. The HD50PX is designed for use in challenging environments. It is IP66 rated for outdoor installations, but can also be installed indoors, mounted directly to a ceiling or wall.

Market Opportunities

The HD50PX is a cost effective surveillance solution for applications that experience changing light conditions throughout the day. The HD50PX offers a simple yet solid design that provides optimum performance for both indoor and outdoor applications including lobbies, atriums, vestibules, gated entrances, foyers, loading bays and driveways.

Features

- 1/3" Interline Transfer CCD
- Super high resolution colour: 600 TV lines
- Built-in fixed lens (f=3.8 mm)
- Digital Noise Reduction technology for noise free images
- Surface mount enclosure, indoors or outdoors
- Vandal-proof and weather resistant housing: IP66 rating
- Auto White Balance
- 3-D axis gimbal
- Two-conductor pigtail is standard for connection to barrel connector
- 12 VDC input



HD50PX

SPECIFICATIONS:

Operational	
Video Standard	PAL
Scanning System	2:1 Interlace
Image Sensor	1/3" Interline Transfer CCD
Number of Pixels (H x V)	752 x 582 (PAL)
Minimum Illumination	0.9 lux
Horizontal Resolution	600 TVL
Video Output	1.0 Vp-p, composite @ 75 Ohms
Sync System	Internal
S/N Ratio	50 dB (AGC Off)
Auto Gain Control	Auto
Automatic Electronic Iris	1/50 – 1/120,000 second (PAL)
White Balance	Auto
Gamma	0.45
Lens Type	Built-in fixed (f=3.8 mm)
Angle of View	H: 70° V: 51°
Electrical	
Input Voltage	12 VDC
Input Range	12 VDC ± 10%
Power Consumption	2.2 W
Mechanical	
Dimensions (W x H x D)	See Diagram
Weight	0.376 kg max
Construction	Housing: Die Cast Aluminium Dome: Polycarbonate Finish: Light grey powder coating
Connector	Main Video: BNC connector Power Input: 2.1 mm Plug

Environmental	
Temperature	Operating: -10°C to 50°C Storage: -20°C to 60°C
Relative Humidity	0% to 90% non-condensing
Rating	IP66
Accessories	
Power Supply	
PSUPER12VDC	12VDC, 500mA - EU & UK Plug
Regulatory	
Emissions	FCC, CE (EN55022) Class A
Immunity	CE (EN50130-4)
Safety	EU: EN 60065

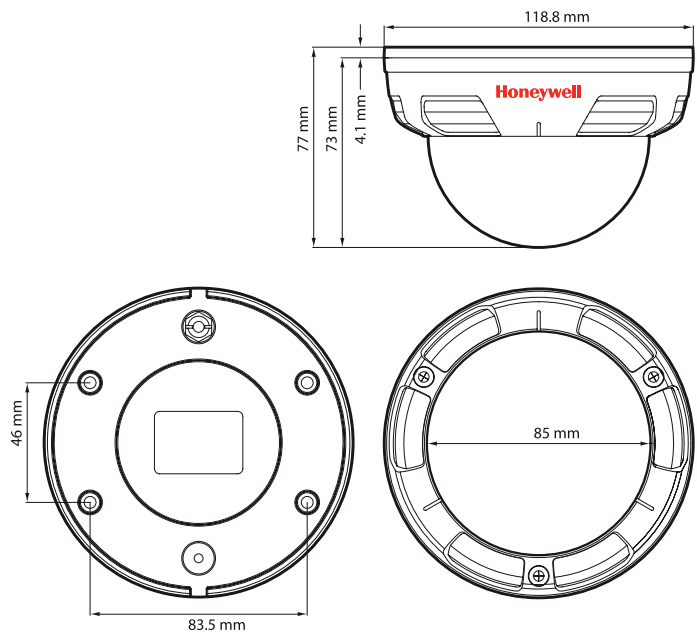

Ordering	
HD50PX	1/3" CCD High Resolution Vandal Mini Dome Camera, 600 TVL, Fixed 3.8mm, 12 VDC, PAL

For additional information:

please visit www.honeywell.com/security/uk

Honeywell Security Group

Aston Fields Road
Whitehouse Industrial Estate
Runcorn
Cheshire
WA7 3DL
Tel: 08448 000 235
www.honeywell.com

HVS-HD50PX-01-UK(1011)DS-C
October 2011
© 2011 Honeywell International Inc.

Honeywell