

HD4CHX

VANDAL RESISTANT DOME CAMERA

Honeywell's HD4CHX is a vandal resistant fixed dome camera that is perfect for indoor and outdoor applications. Loaded with high performance features, the HD4CHX integrates a camera and lens into a single, vandal resistant, compact unit that is easy to install. The rugged scratch-resistant 3.5 mm thick polycarbonate construction can withstand heavy external impacts. In addition, the housing incorporates a new vent that prevents any condensation from forming inside the housing. This innovative camera, with waterproof properties, meets IP66 standards for critical outdoor installations. It comes completely assembled and is designed to mount directly to a ceiling, wall, or to a 4S (using the supplied adapter plate), single, or double electrical box. The unit also comes with a pan/tilt/rotation mechanism and a second video service cable for simple camera adjustments.

This latest addition to Honeywell's 4" mini-dome series responds to the need for a completely integrated, high resolution camera with the widest lens configuration on the market today. The HD4CHX incorporates a 1/3" CCD that offers 540 TV lines of crisp, clear horizontal resolution and a built-in 2.8-10 mm (F1.3) Vari-focal Auto Iris lens to cover a wide range of viewing angles. The HD4CHX accepts both 12 VDC and 24 VAC (auto-sensing). Installing this dome lets you meet all of your application requirements with one high-performing, competitively-priced camera.

Market Opportunities

The HD4CHX is the ideal solution for a wide range of surveillance applications. The compact, one-piece design allows for fast, easy installation in commercial, government, school, professional, and any other quality-sensitive, high-risk environment such as prisons, airports and train stations.

Features

- 1/3" Sony HAD CCD™
- High resolution colour: 540 TVL
- Vandal resistant aluminium alloy housing with polycarbonate dome
- Built-in vent for use in various weather conditions
- Single model instantly converts to flush or surface mount
- Local video output for set-up
- 3-D axis gimbal
- One power connection self-configures to either 12 VDC or 24 VAC. AC line lock standard with all cameras in 24 VAC operation
- Pendant and wall mount kits available



HD4CHX shown with mount ring for surface mount



HD4CHX shown without mount ring for flush mount

HD4CHX

SPECIFICATIONS

Operational	HD4CHX
Video Standard	PAL
Scanning System	625/50 lines
Image Sensor	1/3" Sony Super HAD CCD™ sensor high resolution colour image sensor
Number of Pixels (H x V)	752 x 582 (High Res)
Minimum Illumination (AGC on, 50 IRE)	0.6 lux @ F1.3 (High Res)
Horizontal Resolution	540 TVL High Res
Video Output	1.0 Vp-p, composite @ 75 Ohms
Sync System	12 VDC: Internal, 24 VAC: Line lock
S/N Ratio	50 dB (AGC Off)
Auto Gain Control	On/Off, selectable
Automatic Electronic Shutter	1/50–1/100,000 second (PAL)
White Balance	ATW
Line Lock Phase Adjust	On/Off, switchable
BLC	On/Off, switchable
Flickerless	On/Off, switchable
Gamma	0.45
Lens Type	2.8-10 mm Vari-focal Auto Iris, F1.3
Angle of View	Tele: 34.3° (D), 27.4° (H), 20.5° (V) Wide: 129° (D), 100.2° (H), 73.3° (V)
Electrical	
Input Voltage	12 VDC/24 VAC
Input Range	11-16 VDC, 17-28 VAC
Surge Suppression	1.5 kW Transient
Power Consumption	3.5 W (max)

Mechanical	
Dimensions (W x H x D)	See Diagram
Weight	1.1 kg max
Construction	Housing: Die-cast Dome: Polycarbonate Finish: Light grey powder coating
Connectors	Video Output: BNC connector Power Input: Tinned Leads
Environmental	
Temperature	Operating: -20°C to +55°C Storage: -35°C to +65°C
Relative Humidity	0% to 95% RH non-condensing
Regulatory	
Emissions	FCC, CE (EN55022)
Immunity	CE (EN50130-4)
Safety	UL60065, EU: 2006/95/EC LVD
Accessories	
Mounts	
HD4CHX-WK	Wall mount kit
HD4CHX-PK	Pendant mount kit

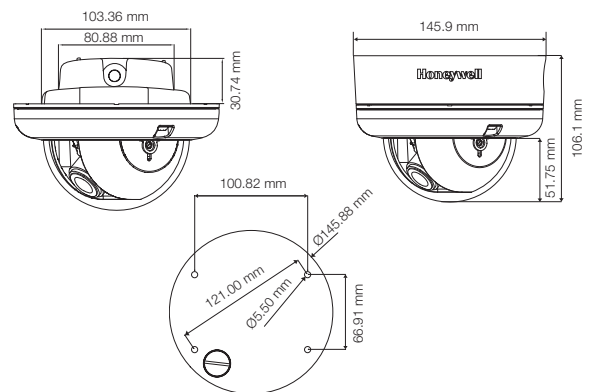

Ordering	
HD4CHX	1/3" CCD High Resolution Vandal Resistant Dome Camera, 540 TVL, 2.8-10 mm VFAI, PAL

NOTE: Honeywell reserves the right, without notification, to make changes in product design or specifications.

For additional information,

please visit www.honeywell.com/security/uk

Honeywell Security Group

Honeywell Systems Group
Aston Fields Road
Whitehouse Industrial Estate
Runcorn
Cheshire
WA7 3DL
Tel: 08448 000 235
www.honeywell.com

HVS-HD4CHX-01-EN(1009)DS-GCSC
October 2009
© 2009 Honeywell International Inc.

Honeywell