

SMT-3222/4022

Professional Large LCD Monitor



I Features

- Support up to 1920 x 1080 resolution(SMT-4022)
- High contrast ratio 4,000:1
- 178 degree horizontal and vertical viewing angle
- Superior image quality DNIe
- HDMI, DVI, RGB and composite inputs
- Built-in Speaker
- Extended video wall format (1x5 ~ 5x5)
- Multi-Language setup support
- Built-in Fan prevents overheating and image corruption
- Anti-image retention mode
- Signal balance function for weak RGB signal

I Dimensions (unit: mm)

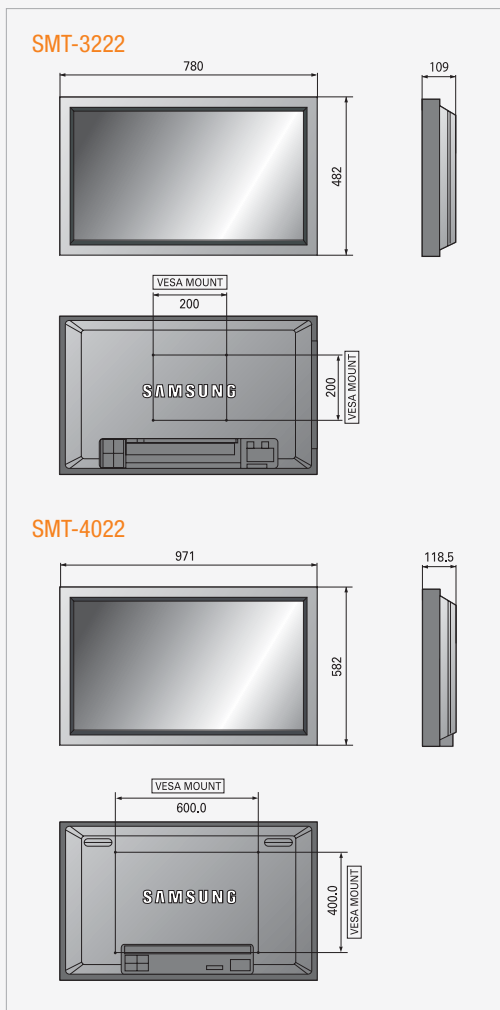

* Foot stand sold separately

I Specifications

Model	SMT-3222	SMT-4022		
General	Screen Size	32"	40"	
	Resolution (HxV)	1366 x 768	1920 x 1080	
	Pixel Pitch (mm)	0.511 x 0.511 (HxV)	0.46125 x 0.46125 (HxV)	
	Brightness(cd/m ²)	450		
	Contrast Ratio	4,000:1 (Dynamic Contrast Ratio 40,000:1)		
	Response Time (ms)	8 (G-to-G)		
	Viewing Angle (H/V)	178° / 178°		
	Panel Lamp Life	50,000HR		
	Display Colors	16.7M		
	Horizontal Frequency	30 ~ 81KHz		
	Vertical Frequency	56 ~ 85Hz		
	Horizontal Resolution	600TV Lines		
	Comb Filter	3D		
Sync Format	NTSC : 3.5 / PAL : 4.43 / Secam			
Feature	Screen Aspect Ratio	4:3 / 16:9		
	Language	English / French / German / Italian / Portuguese / Russian / Spanish / Swedish / Chinese / Japanese / Korean / Turkish / Taiwanese		
	Front Panel Control	Menu, Adjust down / up / left / right, Enter, Source, D.Menu, Power		
	Speaker Output	10W (5W x 2 built-in)	20W (10W x 2 built-in)	
	Indicator	LED (Power)		
	VESA Mount	200 x 200 mm	400 x 600 mm	
	Input Interface	Video	1 composite(RCA), 1 HDMI	
		PC	1 RGB (D-sub), 1 DVI, 1 RS-232	
		Audio	2 RCA	
	Power Requirement	AC100-240V, 50/60Hz		
Power Consumption	130W (Typ), 143W (Max)	180W (Typ), 220W (Max)		
Weight	13.7Kg	19Kg		
Dimensions	Without Stand	780(W)x482(H)x109(D)mm	971(W)x582(H)x118.5(D)mm	
	With Stand	780(W)x545(H)x311(D)mm	971(W)x643(H)x311(D)mm	
Accessories	Remote Control, Battery x 2, Quick Setup Guide, Warranty Card, User's Guide, Power Cord, RCA to BNC Cable			

I Optional Accessory (unit: mm)

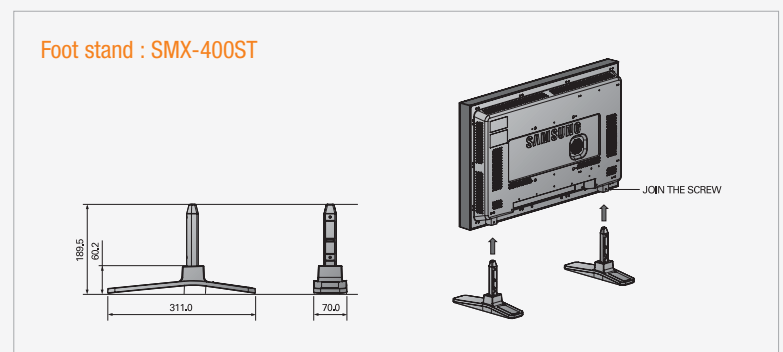

SAMSUNG ELECTRONICS CO., LTD.

416, Maetan 3 Dong, YeongTong-Gu, Suwon City, Kyeonggi-Do, Korea, 443-742
Tel: +82-31-277-3342-3347 Fax: +82-31-277-6597
<http://www.samsungsecurity.com>

Distributed by

* Design and specifications are subject to change without notice