

## GVK-260

**DSP compact colour camera with integrated (22x) aspherical motor-zoom lens**



- Integrated AF lens (22x) /digital zoom (11x)
- Horizontal resolution: 480 TV lines
- Digital signal processing (DSP)
- Digital noise reduction (DNR)
- Digitale image stabilisation (DIS)
- Backlight compensation (BLC)
- Wide dynamic range (WDR)
- Aperture correction (APC)
- High-speed and low-speed shutter control
- Automatic white balance
- Menu-guided setup-programme RS-232/RS-485 and voltage interface

## Dimensions

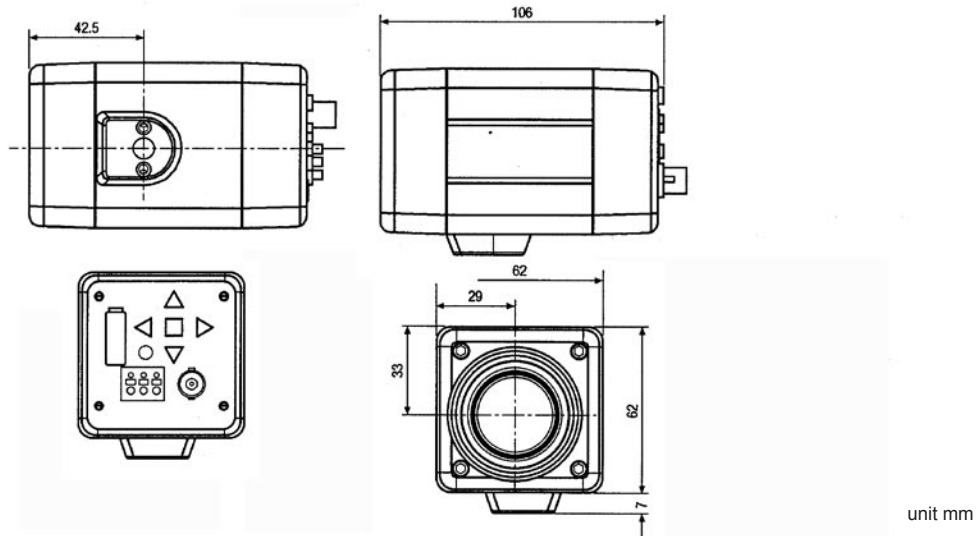

## Technical data

<b>Pick-up device (Chip)</b>	1/4" Sony Super HAD interline transfer
<b>Video standard</b>	CCIR/PAL
<b>Scanning system</b>	2:1 interlaced
<b>Pixel (H x V)</b>	752 x 582 (effective)
<b>Resolution (in lines)</b>	480 (H)
<b>Min. sensitivity</b>	Normal operation: 0,8 Lux, with low-speed shutter: 0,02 Lux measured at F1,6/ 50% (depending on video signal of integrated lens)
<b>Integrated lens</b>	Aspherical motor zoom lens, F 1,6/3,8-83,6 mm (22x zoom )
<b>Digital zoom</b>	11x
<b>Shutter</b>	Selectable, fixed or automatic-electronic from 1/50 to 1/30000 s
<b>Focus</b>	Automatic/manual
<b>Menu settings</b>	PIP, image freeze, digital zoom, digital noise reduction (DNR) positive/negative pattern on/off mirror image (hor.), digital image stabilisation (DIS) wide dynamic range (WDR) or shutter modus
<b>Text insertion</b>	Title, camera no. and status
<b>Synchronisation</b>	Internal
<b>White balance</b>	Automatic (AWB), can be set separately for indoor and outdoor operation or manual wide area white balance (WAWB)
<b>Signal/noise ration</b>	52 dB (AGC off)
<b>Power supply</b>	12 VDC $\pm$ 10 % via separate mains unit
<b>Power draw</b>	4,3 W
<b>Temperature range</b>	-10°C to +50 °C
<b>Dimensions in mm (W x H x D)</b>	62 x 62 x 106
<b>Weight</b>	180 g
<b>Order no.</b>	<b>5.03461</b>

## Accessories

<b>mains unit</b>	FW 7204/12
<b>Order no.</b>	<b>5.03461</b>

Technical alterations reserved