

Video Security

Cameras | Day/Night Cameras

CG-511PA1V

1/3" Day/Night Camera with Switchable IR Cut Filter, DSP, 12VDC/24VAC, 540TVL

Art-No. 92495



Features

Resolution of 540 Horizontal Lines (Colour)
 Automatic Gain Control (AGC)
 High Sensitivity of 0.1Lux at F1.2 (B&W)
 Removable IR Cut Filter
 Back Light Compensation (BLC)
 Electronic Shutter Control (ESC)

Automatic AI/DC Control Selection (Depend on Lens)
 Integrated Eclipse and Flickerless Function
 Automatic White Balance with Hold Function (AWB)
 Auto Blemish Compensation (up to 32 Pixels)
 Adjustable Video Transmission Distance
 Supply Voltage: 12VDC or 24VAC

Specifications

System	CCIR/PAL
Imager	1/3" Sony Super HAD Interline Transfer CCD
Active picture elements	Approx. 440,000, (H) 752 x (V) 582
Signal processing	DSP
Synchronization	Internal/Line lock
Sensitivity at 50% video signal	0.8Lux (Colour); 0.1Lux (b&w) at F1.2
Horizontal resolution	540 TV lines (Colour); 560TVL (b&w)
Signal-to-noise ratio	48db (AGC OFF)
Gamma correction	0.6/1.0
OSD function control	OSD camera setup: Pixel correction, Eclipser, Day&Nignt, BLC, AWB, Chroma, ESC, AGC, Flickerless, Aperture, Masking (Window blanking), Transmission distance compensation
IR cut filter	Motorized, switchable filter. Automatic function depend on the amount of light. Automatic/manual selectable by OSD menu. In removed filter position, the colour signal will be switched off. Selectable time delay: 5Sec. or 30Sec., External D&N switching via external contact input
Automatic gain control (AGC)	Normal, High and ON/OFF switchable

CG-511PA1V

(Specifications continued)

Aperture Correction (APC)	Horizontal and vertical
Flickerless function	120sec., ON/OFF switchable
Blemish compensation	Automatic blemish detection and compensation (for up to 32 pixels)
Eclipser function	ON/OFF, Treshold, Eclipse and Grey level
Electronic shutter control (ESC)	2.000:1 (ON/OFF switchable)
Light control range (AI + AGC)	600,000:1 (Iris range F1.4 to F300)
Light control range (ESC + AGC)	30,000:1
White balance (AWB)	Auto/Hold
Backlight compensation (BLC)	ON/OFF switchable
External adjustments	Flange focus; Switch for setup menu
Signal amplification	3 steps (for transmission distance short, middle, long)
Video output	1Vp-p, (C)VBS, 75ohms
External connections	Auto-/DC Iris (4-pin), Video (BNC), Day/Night switching (2-pin), Power input
Usable iris controls	Manual iris, Auto-Iris (ESC OFF), DC controlled (automatic detection)
Auto-Iris voltage supply	9VDC (40mA max.)
Supply voltage	12VDC +/-15% ; 24VAC +/-15%, 50Hz
Power consumption	Approx. 4.8watts (at 12VDC)
Camera mount	1/4" - 20UNC thread on top and bottom
Temperature range	-10°C ~ +50°C (0 ~ +40°C: Specifications guaranteed)
Dimensions (HxWxD)	See drawing
Weight	200g
Parts supplied	4-pin plug

Accessories

77779 / VT-PS12DC-UK	Power Supply Unit w. UK Mains plug-in, 100-240VAC/12VDC-1.0A, Regul., open Ends
70769 / WD-22	Wall Mount Bracket with Ball Joint, 1/4" Camera Fixing Screw, Beige Grey
70448 / VT-PS12DC-6	Plug-in Power Supply Unit 100-240VAC 12VDC (1.0Amp), Regulated, w. Open Ends
70771 / WD-23	Wall Mount Bracket with Ball Joint, 1/4" Camera Fixing Screw, Pantone 877
77772 / VT-PS12DCDT	PSU 12VDC/0,5A, Regulated, Desktop Version, 1.8m Cable each w. open ends

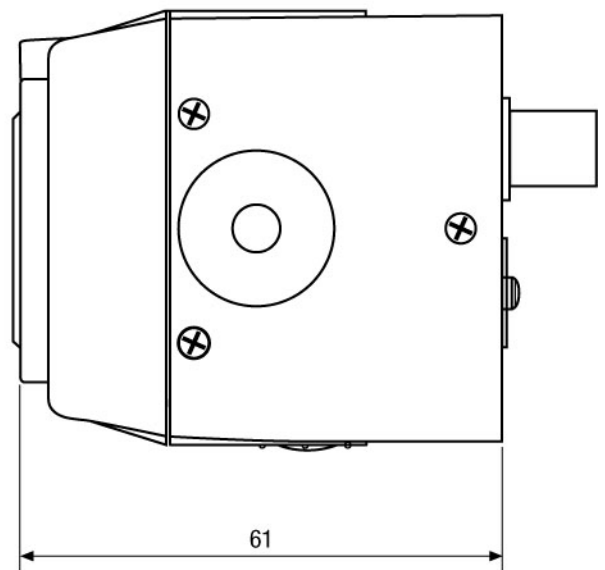
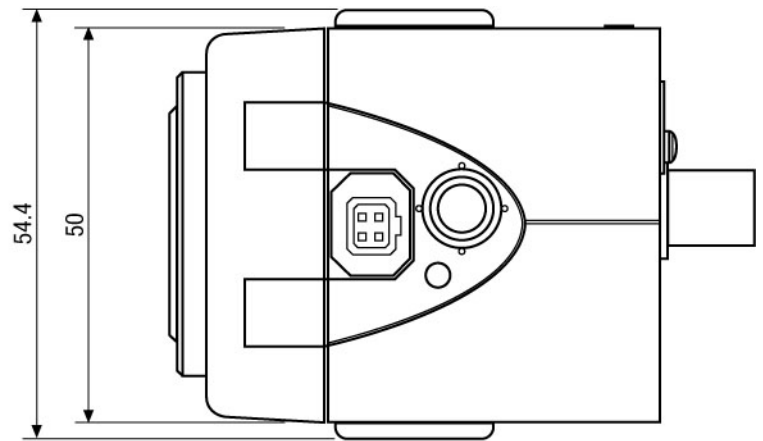
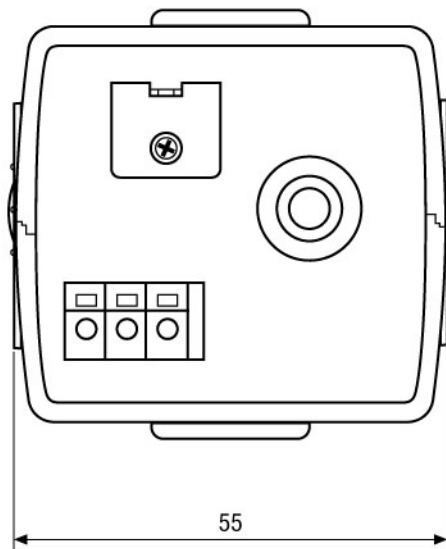

Maße/Dimensions: mm

VIDEOR TECHNICAL E. Hartig GmbH
 Carl-Zeiss-Straße 8 · 63322 Rödermark · Germany
 Telefon +49 (0) 60 74/8 88-0 · Telefax +49 (0) 60 74/8 88-100
 info@videortechnical.com · www.videortechnical.com