



GE Interlogix Fiber Options

Core Product



S700V



& S702V

Video Transmission System



Product Specification

Features

- ✓ One-way video transmission
- ✓ One or two video channels
- ✓ Supports NTSC and PAL video formats
- ✓ Works with all cameras
- ✓ Optical AGC circuitry
- ✓ Transmits up to 3.2 mi (5.2 km)
- ✓ Standalone or rack modules
- ✓ SMARTS™ Diagnostics
- ✓ Forever Warranty™

Description

The S700V Series meets the challenge for a low cost, high performance fiber optic video transmission system. The series transmits one or two channels of baseband composite video up to 3.2 miles (5.2 km). The S700V is available in four versions: (1) standalone modules providing one video channel on one fiber, (2) standalone modules providing two video channels on two fibers, (3) rack-mounted cards providing one video channel on one fiber, and (4) rack-mount cards that support two video channels on two fibers.

Fiber Option's unique **SMARTS™** Technology provides built-in diagnostics.

Basic Model Descriptions

S700V 1-Fiber link, 850 nm
S702V 2-Fiber link, 850 nm

SYSTEM DIAGRAMS*

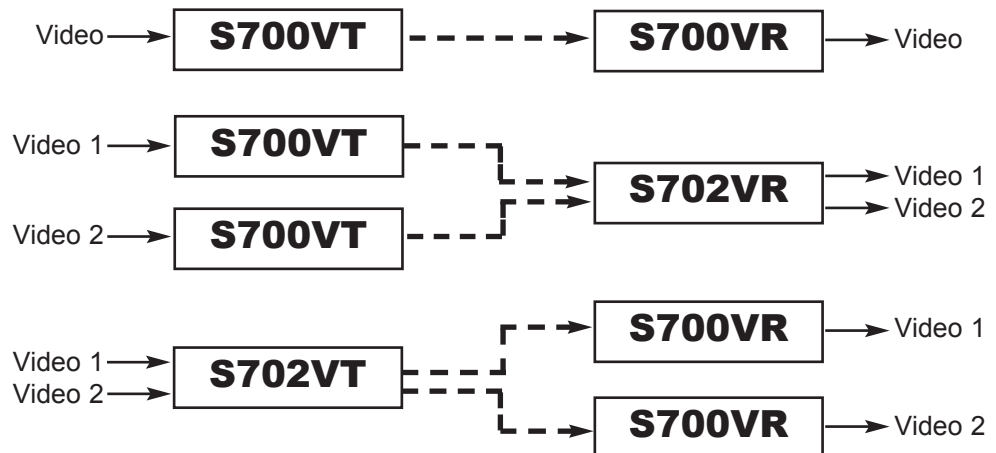

* Note: A single S702VT transmitter may also be used to interface with a single S702VR-R receiver.

SERIES S700V AND S702V

VIDEO

Number of Channels:	
S700V:	1
S702V:	2
Standards Supported:	NTSC, PAL
Video Input Signal:	1.0 V p-p composite
Video Output Signal:	1.0 V p-p composite, unity gain
Input/Output Impedance:	75 Ω
Signal-to-Noise Ratio:	>50 dB @ max path loss
Video Bandwidth:	8 MHz
Video Resolution:	>640 TV lines
Differential Phase:	3°
Tilt:	1.6%

ELECTRICAL

Input Voltage:	
Standalone Modules:	
S700V, S702VT:	12 - 14 VAC or 13.5 VDC, regulated
S702VR:	13.5 VDC, regulated
Rack Modules:	13.5 VDC, regulated
Current Requirement:	
S700VT:	50 mA
S700VR:	200 mA
702VT:	100 mA
702VR-R:	440 mA
Rack Module Power Factor:	
S700VT:	1
S700VR:	2
S702VT:	1
S702VR-R:	4
Power Consumption:	
S700VT:	0.7 W
S700VR:	2.8 W
702VT:	1.4 W
702VR-R:	5.6 W
Card Replacement:	Cards are hot swappable
Power Supply:	610P (AC) 613P (DC)

OPTICAL

Wavelength:	850 nm
Optical Mode:	Multimode
Optical Budget*:	13 dB standard

*Optical Budget based on 62.5/125 μ m fiber,
for 50/125 μ m fiber subtract 3 dB.

**Operating distance is approximate and assumes best
fiber. It will be affected by the type and number of
splices in the fiber. Refer to update no. TB00-005,
which can be found at www.fiberoptions.com.

Operating Distance**:	3.2 mi (5.2 km)
Emitter Type:	LED
Fiber Type:	62.5 μ m
Gain Control:	Optical automatic (OAGC)

ENVIRONMENTAL

Temperature Range	
in Operation:	-40° to +167° F (-40° to +75° C)
in Storage:	-40° to +185° F (-40° to +85° C)
Humidity Range in Operation and Storage:	0 to 95% relative, noncondensing

MECHANICAL

Standalone S700V, S702VT Modules

Dimensions:	Length: 5.0 in (127 mm) Width: 2.8 in (71 mm) Height: 1.5 in (38 mm)
Weight:	0.6 lb (0.27 kg)
Construction:	Plastic
Mounting Method:	Two No. 6 (3 mm) screws

Standalone S702VR Modules

Dimensions:	Length: 9.31 in (237.5 mm) Width: 6.33 in (161 mm) Height: 1.95 in (50 mm)
Weight:	1.4 lb (0.64 kg)
Construction:	Aluminum
Mounting Method:	Four No. 6 (3 mm) screws

Rack Modules

Module Width:	1 slot, 1.0 in (25.4 mm)
Weight:	
S700V:	0.50 lb (0.27 kg)
S702V:	0.61 lb (0.28 kg)
Construction:	Aluminum
Finish:	Black semigloss paint

SMARTS™ INDICATORS

Level/Loss™, Video, Power (Standalone TX only)

AGENCY COMPLIANCE AND MTBF

Emissions:	FCC Part 15, ICES-003, AS/NZS 3548, EN55022
Immunity:	ENV50204, EN61000-4-2, 3, 4, 5, 6, 11
Safety:	UL1950, CAN/CSA 22.2, NO.950-95
MTBF:	>100,000 hours



For additional information about this product, refer to the Fiber Options Web site at www.fiberoptions.com.