

VKCD-1332SM/3.8

Article-No.: 92571

1/3" Dome, Fixed, Day&Night, 3,8mm
Lens, 600TVL, 12VDC

Main features

1/3" Sony Super HAD II CCD
Automatic Gain Control (AGC)
High Speed Shutter Control (ESC)
Manual 3-axis Camera Gimbal
Supply Voltage: 12VDC

Sensitivity of 0.22Lux at F1.2 (Colour & B/W)
Backlight Compensation (BLC)
Automatic White Balance (AWB)
Integrated Fix Lens: F2.0/3.8mm
Dome Bubble Size: 85mm Diameter



Specifications

Video standard	PAL
System	Day&Night
Sensor size	1/3"
Imager	CCD
Imager	Sony Super HAD II Interline Transfer
Active picture elements	440,000 (H) 752 x (V) 582
Synchronization	Internal
Signal-to-noise ratio	50dB (AGC OFF)
Sensitivity (at 50% video signal)	0,2 Lux
Sensitivity (at 50% video signal)	(colour) at F1.2 (measured)
Horizontal resolution	600 TVL
Rotation range	359°
Automatic gain control (AGC)	supplied
Automatic electronic shutter (ESC)	1/50 ~ 1/120,000sec.
Low Speed Shutter	no
Digital Noise Reduction (DNR)	no
Automatic white balance (AWB)	Available
Backlight compensation	no
Wide Dynamic Range (WDR)	no
Aperture Correction (APC)	Horizontal and vertical
IR cut filter	OLPF (Overlay Low Pass Filter)
Video outputs	Composite (CVBS)
Video outputs	1Vp-p, (C)VBS, 75ohms, BNC
Lens mount	integrated lens
Lens type	fixed focal length
Focal length	3,8 mm
Horizontal angle of view	65°
Aperture range (F)	F2.0
Iris control	no
MOD (Minimum object distance)	0,1 m

Specifications (continued)

Filter screw size	not available
Cable connection	Video (BNC), 12VDC (DC jack)
Serial interfaces	no
Temperature range (Operation)	-10°C ~ +45°C
Heater	no
Protection rating	IP44
Protection rating	at installation according to the manual
Supply voltage	12VDC
Supply voltage	12VDC (10 ~ 15VDC), 12VDC ±0.5V recommended
Power consumption	1.2W
Vandalism resistant	no
Bubble	Polycarbonate plastic with black inner liner
Colour (bubble)	clear
Camera adjustment	3-axis camera adjustment
Mounting	ceiling mount, wall mount
Housing	Indoor
Housing material	Plastic
Colour (housing)	light grey
Dimensions (HxWxD)	See drawing
Weight	210g
Parts supplied	Screw set, Drilling template, Manual
Certificates	CE

Optional Accessories

Image	Artikel-Nr. / Typ	Description
	VT-PS12DC-8	Plug-in Power Supply Unit 100-240VAC 12VDC (1.0Amp), Regulated, with DC Plug
	VT-PS12DC-7	Plugable PSU w. Cont. & UK Mains plug-in 100-240VAC/12VDC-1.25A, Regulated
	VT-PS12DCDT1	PSU 12VDC/1.0A, Regulated, Desktop Version, 1.8m Cables each w. open ends

Technical Drawing

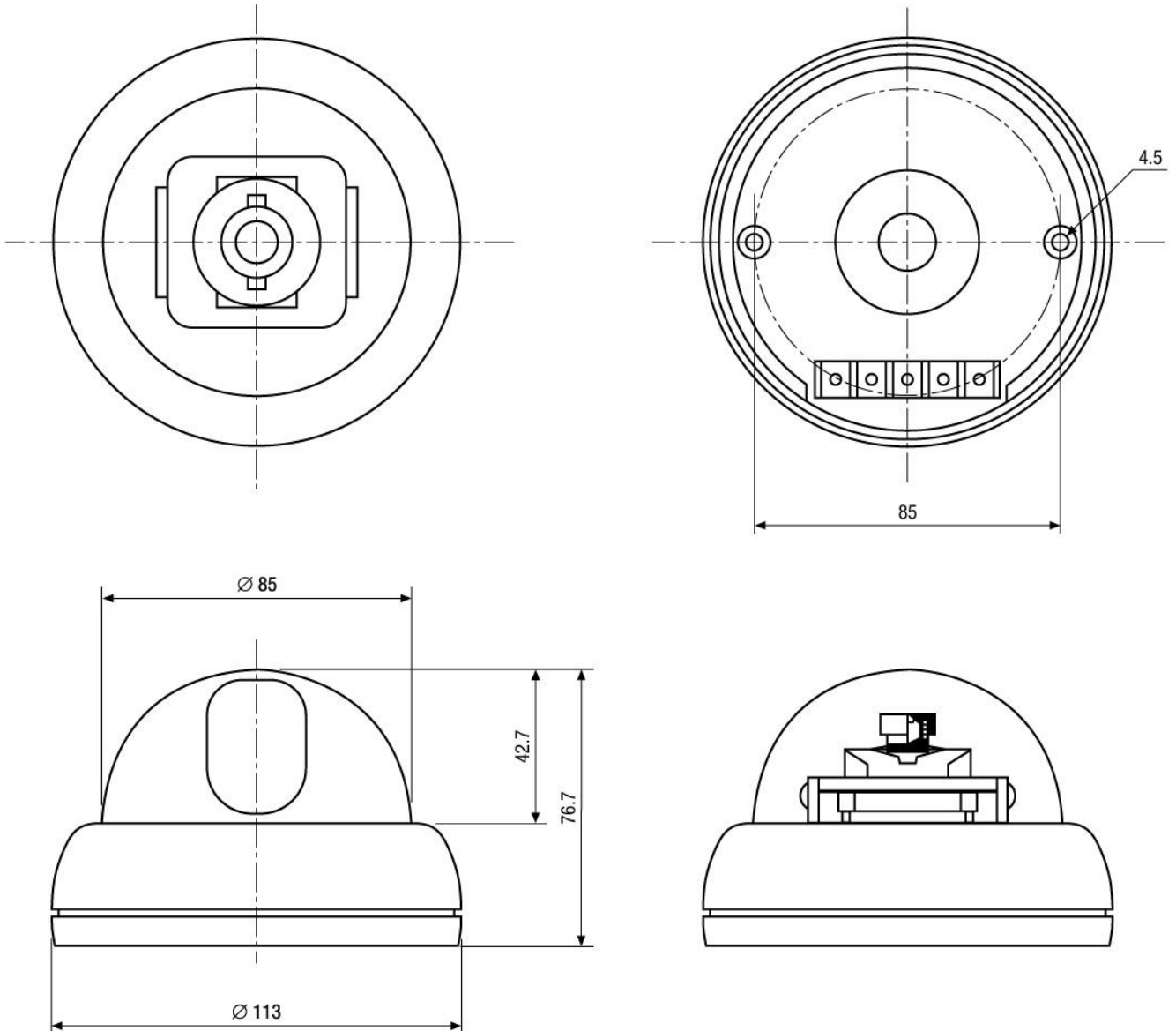

Maße/Dimensions: mm



Your partner for eneo products:

