



## VHM/DP-ECL210-W

Article-No.: 79673

Dustproof Housing (210mm),  
RAL9016/RAL 7035

### Mainfeatures

Camera protection  
Fold-down housing body  
Insulated camera mounting  
Window glass with "Clear-Shield" technology  
Housing colour: RAL9016/RAL7035

Housing body length: 210mm  
4 levels of camera height adjustment  
3 cable entries M16x1.5mm  
Incorporated carrier handle  
Option: cable distributor board





### Specifications

Series	eneo VHM
Maximum installation length	210
Space for power supply	NE-112 (1 output): 85mm; NE-112/2 (2 outputs): 110mm
Cable entries	3x M16x1.5mm
Window screen	coated with "Clear Shield" technology, with this technology the glass corrosion, caused by environmental pollution, is avoided and screen cleaning cycles will be extended; the coating is UV light resistant, colour neutral and it causes no F-stop loss
Clear Shield	yes
Window heater	no
Blower	no
Wiper	no
Sunshield	no
Hidden cable management	no
Integrated wall mount	no
Protection rating	IP66
Housing	indoor

## Specifications (continued)

Housing material	aluminium
Housing	aluminium with plastic covers (ABS)
Colour (housing)	RAL9016, RAL7035
Dimensions (HxWxD)	see drawing
Weight	1.3kg
Parts supplied	Screw set, 3mm Allen key

## Optional Accessories

Image	Artikel-Nr. / Typ	Description
	WD-16/MK-W	Wall Mount with Swivel Head for VHM Weatherproof Housings, RAL9016
	NE-112/AC24V	Power Supply Unit 230VAC/24VAC (600mA) for VHM Housing
	NE-112/2	Power Supply Unit 230VAC/12VDC (600mA), Regulated, 24VAC (1000mA) f. VHM Housing
	NE-112	Power Supply Unit 230VAC/12VDC (600mA) for VHM Housing, Regulated
	VHM/KV2	Cable Connection Board with Thermostat for VHM Housing, "EC" Series

## Technical Drawing

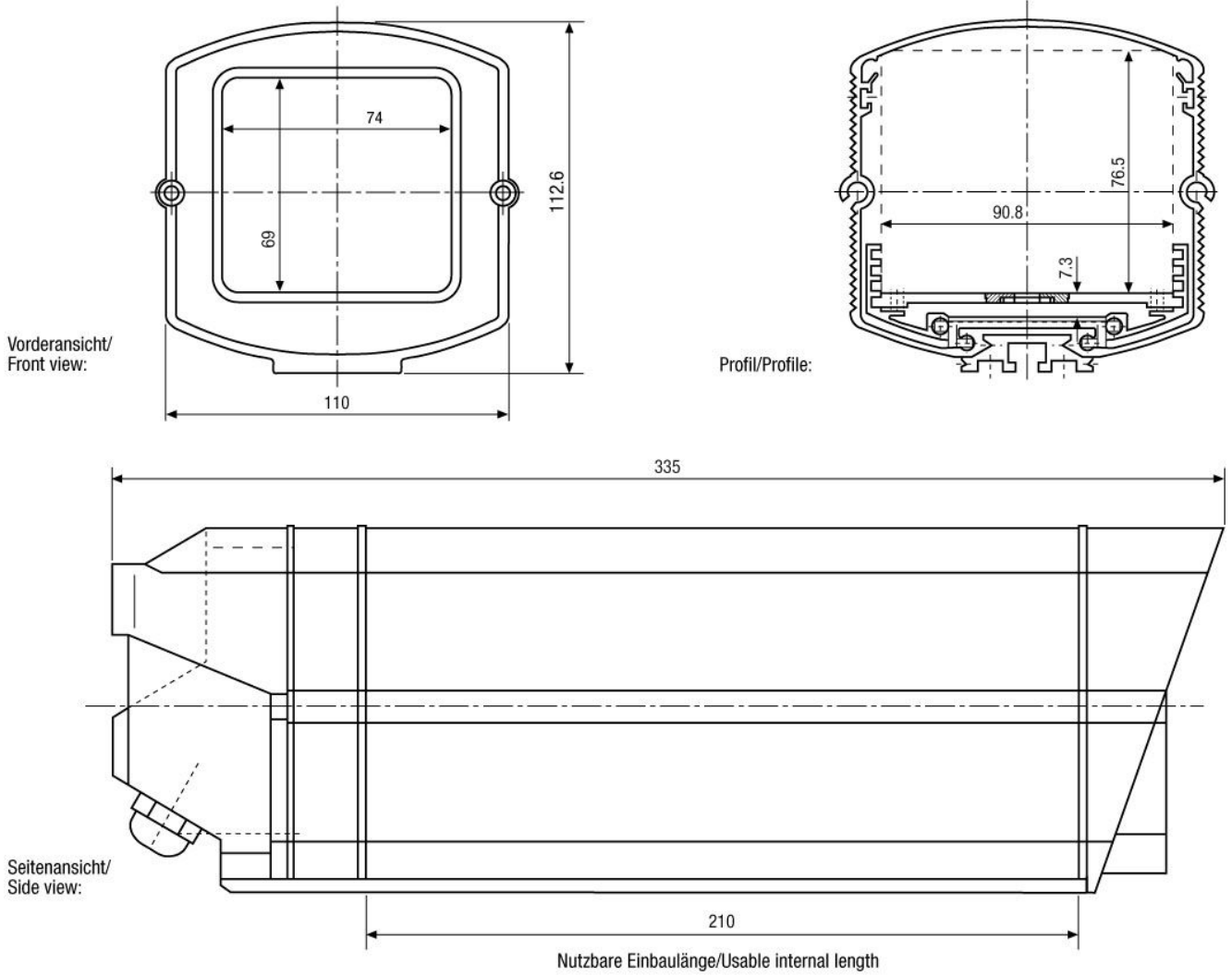

Maße/Dimensions: mm

Your partner for eneo products:

