



Weatherproof Housings (Large)

FDP-No.: 79478

VHB-1ECL

- Camera Weatherprotection
- Fold-down Housing Body
- 4 Levels of Camera Height Adjustment
- Housing Body Length: 350 mm
- 3 Cable Entries
- Insulated Camera Mounting
- Screen Heater Included
- Varnished: RAL 7032



Wall bracket is not included with the housing

Specifications:

Housing length (L)	350 mm
Maximum installation length	360 mm
Necessary space for PSU	80 mm
Cable entries	3x PG9
Screen heater	110-265 V
Sunshield	Yes
Protection rating	IP 66
Housing	Aluminium
Colour	RAL 7032
Dimensions (HxWxD)	See drawing
Weight	4.9 kg

Accessories

EDP No. / Type	Description
73064 WD-16/MK	Wall bracket with swivel head, recommended for housings VHB/VHM, light grey finish (RAL 7032)
71627 VHB/H24	Window heater 12-30 VAC/DC for VHB housing series

VHB-1ECL

EDP No. / Type	Description
79274 VHL-VHB/KVS	Screw terminal PCB for VHL/VHB housing series, with fuse 1,25 A
79046 VHL-VHB/KV	Screw terminal PCB for VHL/VHB housing series
79047 VHB/ACS	Double glazed front window for VHB housings
79281 VHL-VHB-VHM/TH2	Thermostat switch for VHB/VHL/VHM housings, switching points: +16°C (On), +20°C (Off)
79334 NE-105S	Power supply unit 12 VDC-600mA stabilized output voltage, with fuse 1.25 A, suitable for VHB housing series
79542 VHB/WP-1	Screen wiper for VHB housing series, 230 VAC/50 Hz
79539 VHB/WP-2	Screen wiper for VHB housing series, 24 VAC/50 Hz
79463 VHM/WA-2	Screen washer unit for WP-1/-2 (VHM and VHB housing series)
77372 VHB-W/230V	High pressure window washer system, suitable for VHB and VHM housing series
70599 VZS-6	Plugable twisted-pair video signal transmitter, 1 coaxial input, 1 TP output, 12 VDC

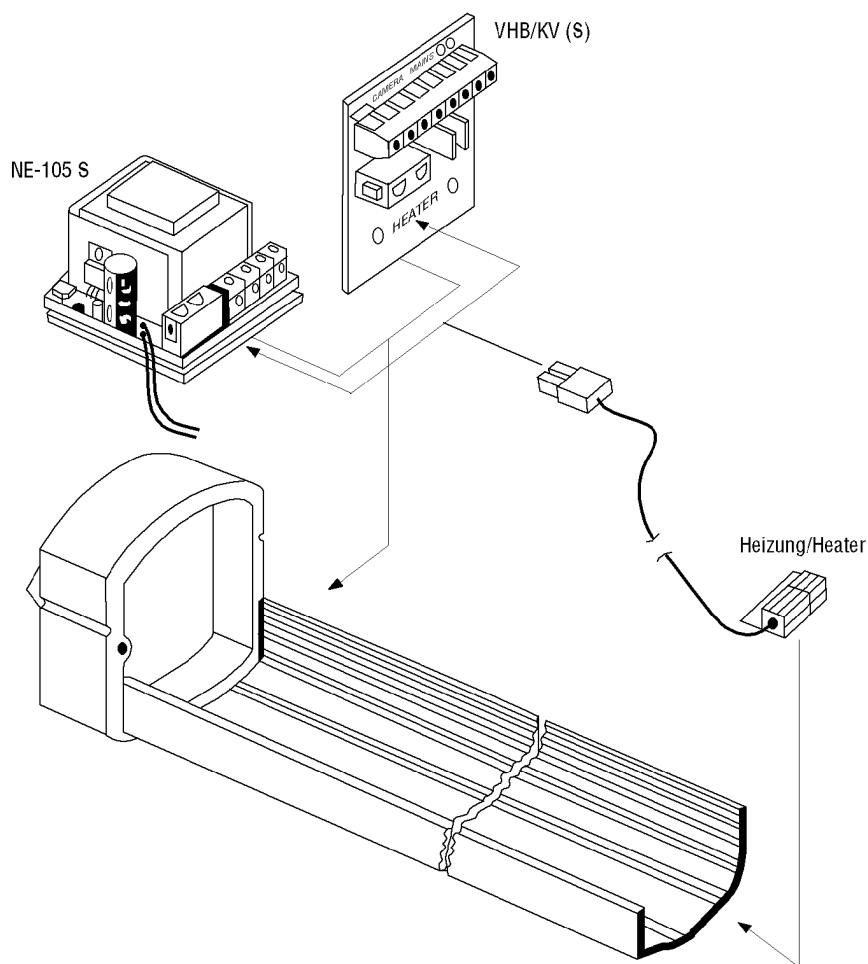
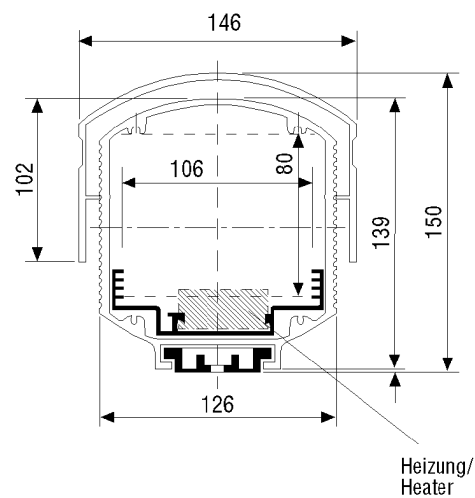
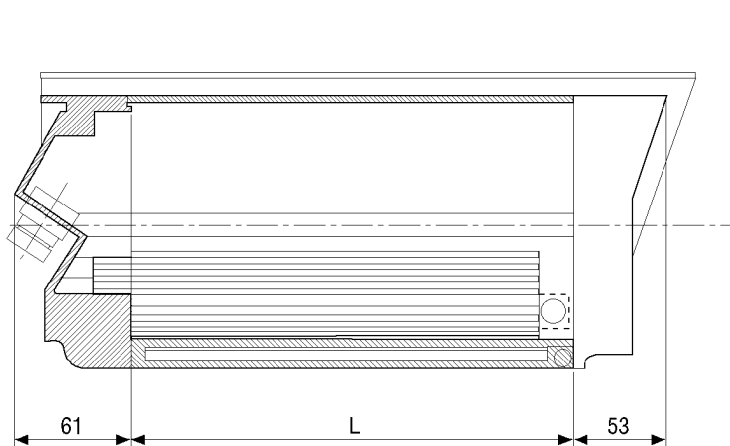

Maße/Dimensions: mm

e-mail: info@eneo-security.com • www.eneo-security.com