

AI Controlled Lenses

FDP-No. : 43147

G0308NDAI

- Suitable for 1/2" and 1/3" Colour and B&W Cameras
- CS Mount
- High Standard of Optical and Mechanical Quality
- Aspherical lens
- Built-in Auto Iris Amplifier
- Adjustable Slip-ring Mount for Cable Positioning



Specifications:

Focal length (f)	3.8 mm
Aperture range (F)	F0.8-F360
Mount	CS
Nominal format size	1/2"
Flange focal length	12.5 mm
Horizontal angle of view at nominal format size	89.2°
Minimum object distance (M.O.D.)	0.15 m
Screw-in depth	B&W: 7.0 / Colour: 3.5 mm
Filter screw size	M43x0.75 mm
Slip-ring mount	340°-360° Variable adjustment range
Iris control system	Galvanometer
Supply voltage	8-16 VDC
Input signal range	0.5 to 1.0 Vp-p (C)CVS
Max. current consumption	35 mA
Response time	<2 sec.
Accuracy at +20°C	+/-15 %
Cable length	350 mm
Dimensions (LxDxH)	53x45x33 mm
Temperature range	-20°C to +50°C
Weight	160 g

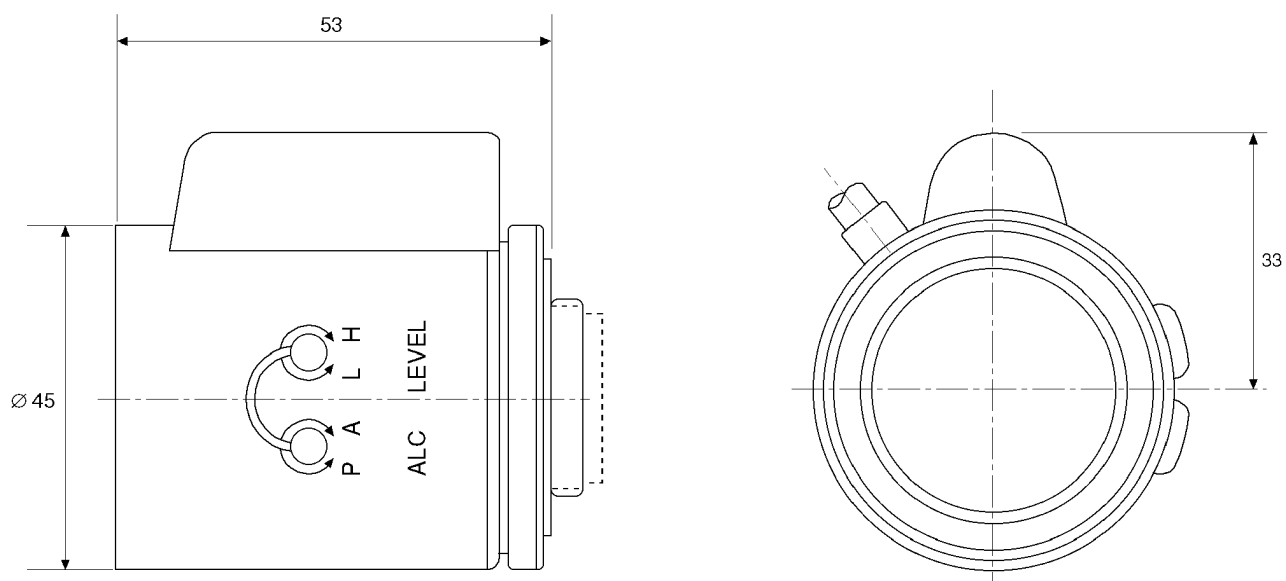

Maße/Dimensions: mm

e-mail: info@eneo-security.com • www.eneo-security.com