

AI Controlled Lenses

FDP-No. : 47115

A1214NDAI/IR

- Suitable for 1/2" and 1/3" Black & White Cameras
- C Mount
- High Standard of Optical and Mechanical Quality
- IR Corrected Lens
- Built-in Auto Iris Amplifier
- Adjustable Slip-ring Mount for Cable Positioning



Specifications:

Focal length (f)	12 mm
Aperture range (F)	F1.4-F125
Focus constant range	400 bis 900 nm
Mount	C
Nominal format size	1/2"
Flange focal length	17.526 mm
Horizontal angle of view at nominal format size	27.9°
Minimum object distance (M.O.D.)	0.3 m
Screw-in depth	8.5 mm
Filter screw size	M37.5x0.5 mm
Slip-ring mount	340°-360° Variable adjustment range
Iris control system	Galvanometer
Supply voltage	8-16 VDC
Input signal range	0.5 to 1.0 Vp-p (C)CVS
Max. current consumption	35 mA
Response time	1.5 sec.
Accuracy at +20°C	+/-15 %
Cable length	>50 cm
Dimensions (LxDxH)	36,5x40x31,5 mm
Temperature range	-20°C to +50°C
Weight	100 g

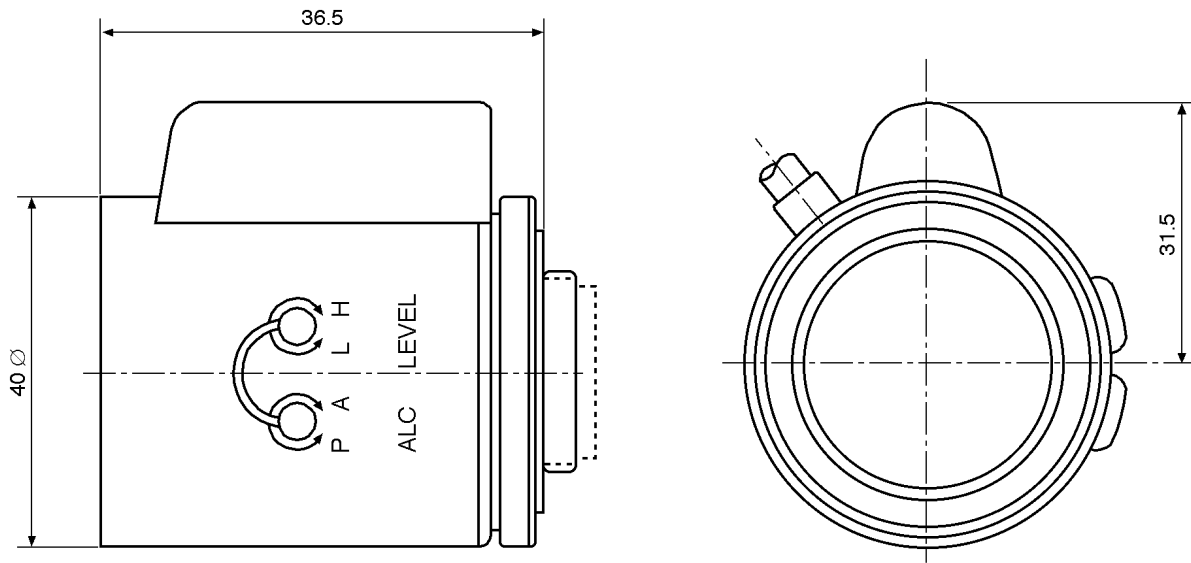

Maße/Dimensions: mm

e-mail: info@eneo-security.com • www.eneo-security.com