

Dennard Washer Unit



DENNARD WASHER UNIT

The Dennard washer unit is designed to accompany Dennard wiper units. Together they provide a complete window wash/wipe system for the Dennard range of outdoor enclosures.

The washer units are supplied with 10 metres of tubing to allow direct connection to the washer jet on the wiper unit.

The washer bottles are UV stabilised and suitable for prolonged exposure to sunlight.

FEATURES

- ▶ Washer pumps available in 230V, 110V & 24V options
- ▶ 2 year warranty
- ▶ Available in 5 litre or 25 litre versions
- ▶ Built in fuse protection
- ▶ Supplied with 10 metres tubing
- ▶ Maximum recommended pumping height 8 metres
- ▶ Stainless steel fixings
- ▶ Weatherproof. BS. EN 60529 level IP65 (no water ingress)

OPTIONS

DM/94072 = 5 LITRE WINDOW WASH 230V

DM/94073 = 5 LITRE WINDOW WASH 110V

DM/94074 = 5 LITRE WINDOW WASH 24V

DM/94075 = 25 LITRE WINDOW WASH 230V

DM/94076 = 25 LITRE WINDOW WASH 110V

DM/94077 = 25 LITRE WINDOW WASH 24V

ACCESSORIES

H045 = 5 LITRE BOTTLE

H045 = 25 LITRE BOTTLE

H048 = NON-RETURN VALVE

DM/95079 = WASHER PUMP 240V

DM/95080 = WASHER PUMP 110V

DM/95081 = WASHER PUMP 24V

H047 = WASHER TUBE Ø 1/8" FOR PUMP TO HOUSING

H047 = WASHER TUBE Ø 5/32" FOR BOTTLE TO PUMP

SPECIFICATION

MATERIAL

Mild steel, zinc plate
Bottle UV stabilised polyethylene

FINISH

Powder coated and stoved.
Ash Grey, leatherette finish to BS4800 00-A-01

TOTAL POWER CONSUMPTION

40VA

ENVIRONMENTAL PROTECTION

BS. EN 60529 level IP65 (no water ingress)

CONNECTION

2 metre flying lead with cable gland entry

WEIGHT

94072+ (5L)	94075+ (25L)
5.5kg (empty)	14kg (empty)
10.5kg (full)	39kg (full)

DIMENSIONS FOR 5L UNIT

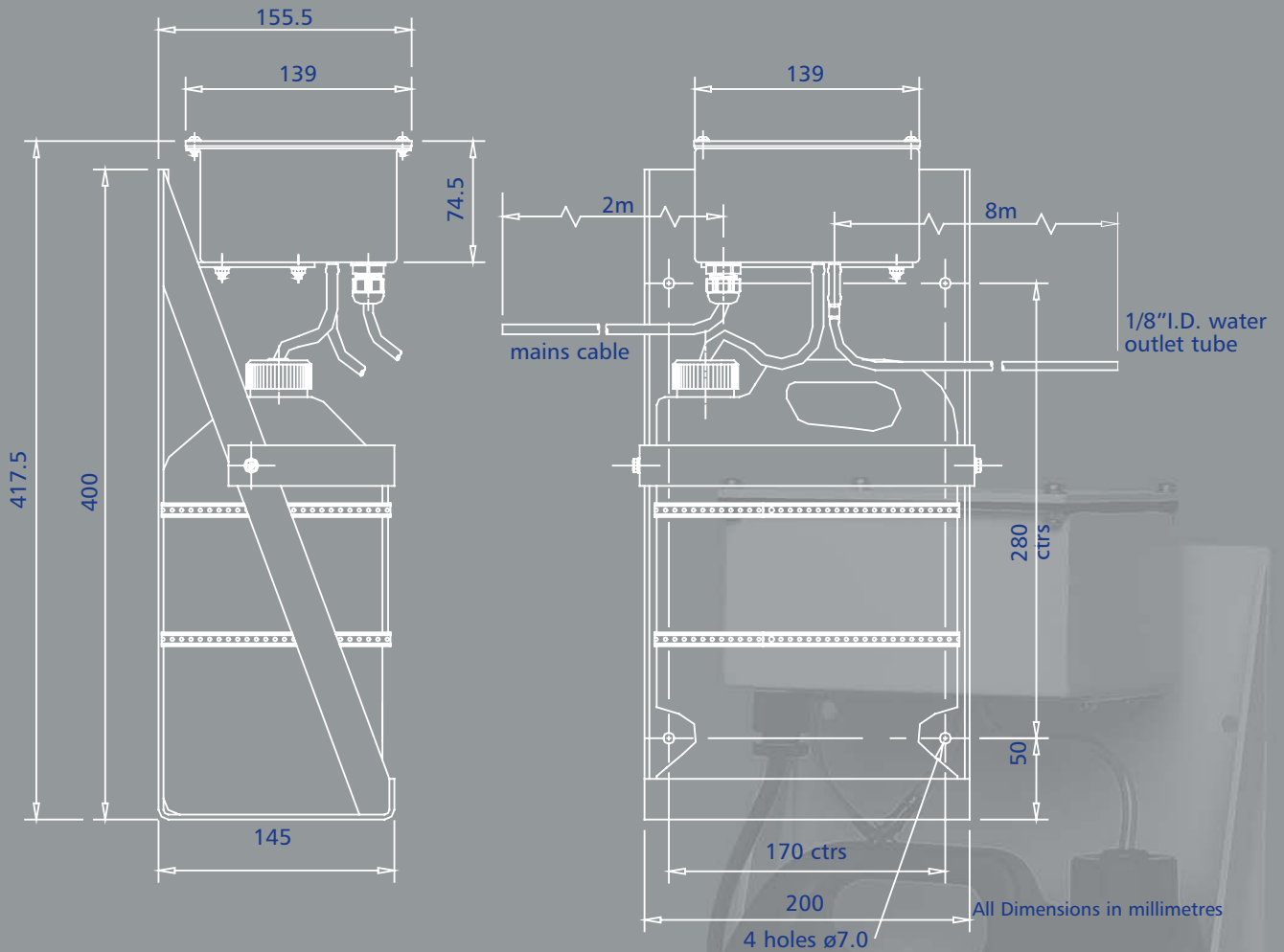

PLEASE CHECK THE WEBSITE FOR DETAILS OF COMPATIBLE PRODUCTS AND OTHER LATEST DEVELOPMENTS

FOR FURTHER INFORMATION PLEASE CONTACT

Dedicated Micros UK
Dedicated Micros USA

Dedicated Micros Germany
Dedicated Micros France
Dedicated Micros Asia
Dedicated Micros Australia
Dedicated Micros Malta
Dedicated Micros Middle East

Dedicated Micros Slovenia
Dedicated Micros Benelux

11 Oak Street, Swinton, Manchester M27 4FL UK Tel: +44 (0) 845 600 9500 Fax: +44 (0) 161 727 3300.

14434 Albemarle Point Place, Suite 100, Chantilly, Virginia 20151 USA Freephone: 800 864 7539
Tel: +1 703 904-7738 Fax: +1 703 904-7743 and 23456 Hawthorne Blvd. Suite 100, Torrance, CA 90505,
Tel +1 310 791-8666 Fax: +1 310 791-9877.

Neckarstraße 15, 41836 Hückelhoven, Germany Tel: +49 243 352 580 Fax: +49 24 33 52 58 10.

9-13 rue du Moulinet, 75013 Paris, France Tel: +33 1 45 81 99 99, Fax: +33 1 45 81 99 89.

16 New Industrial Road, #03-03 Hudson Techno Centre, Singapore 536204 Tel: +65 62858982 Fax: +65 62858646.

5/3 Packard Avenue, Castle Hill, NSW 2154, Australia Tel: +612 9634 4211 Fax: +612 9634 4811.

UB 2, San Gwann Ind. Est., San Gwann, Malta Tel: +356 21483 673 Fax: +356 21449 170.

Building 12, Suite 302, P.O.Box 500291, Dubai Internet City, Dubai, United Arab Emirates
Tel: +971 (4) 390 1015, Fax: +971 (4) 390 8655.

Delavska cesta 24, 4208 Sencur, Slovenia Tel: +386 4 279 18 90 Fax: +386 4 279 18 91.

Joseph Chantraineplantsoen 1, 3070 Kortenberg, Belgium Tel: +32 2751 3480 Fax: +32 2751 3481.



www.dedicatedmicros.com

The manufacturer reserves the right to change the specification without notice.



All trademarks are courtesy of registered owners.
The DM logo is a trademark of Dedicated Microcomputers group Ltd.
MKT-WASH-D-001E