

Dennard 506



DENNARD 506 CAMERA HOUSING

The Dennard 506 housing is specifically designed to accommodate a range of cameras. The enclosure incorporates a removable top cover for camera access, similar to our Dennard 515 housing.

Units are constructed from pretreated steel sheet, powder coated and stoved. The standard specification includes a heater, two cable glands, adjustable camera platform and stainless steel fixings throughout. Environmental protection is to IP65 .

FEATURES

- ▶ **Constructed from pretreated steel sheet**
- ▶ **Finish: powder coated & stoved**
- ▶ **Three latch cover retention**
- ▶ **Window heater / demister**
- ▶ **Stainless steel fixings**
- ▶ **2 year warranty**
- ▶ **Weatherproof - BS.EN 60529 Level IP65 (no water ingress)**
- ▶ **Horizontal and vertical camera platform adjustment**

OPTIONS	ACCESSORIES	
DM/506-600 = HOUSING FOR 12-24V OPERATION	DM/317 = WALL BRACKET 10KG LOAD	H003 = SPARE WIPER BLADE
DM/506-701 = HOUSING FOR 110-230V OPERATION	DM/428 = WALL BRACKET 15KG LOAD	DM/94072 = 5 LITRE WINDOW WASH 230V
	DM/94049 = FAN ACCESSORY KIT 12-24V	DM/94073 = 5 LITRE WINDOW WASH 110V
	DM/94050 = HEATER 12-24V	DM/94074 = 5 LITRE WINDOW WASH 24V
	DM/94051 = HEATER 110-230V	DM/94075 = 25 LITRE WINDOW WASH 230V
	DM/94052 = ANTI-TAMPER SWITCH	DM/94076 = 25 LITRE WINDOW WASH 110V
	DM/94069 = WIPER 230V	DM/94077 = 25 LITRE WINDOW WASH 24V
	DM/94070 = WIPER 110V	DM/95029 = REPLACEMENT DEMISTER 12-24 VAC
	DM/94071 = WIPER 24V	DM/95030 = REPLACEMENT DEMISTER 110-230 VAC

SPECIFICATION

MATERIAL

Pretreated steel sheet

FINISH

Powder coated and stoved
Ash Grey leatherette finish to BS4800 00-A-01

WEIGHT

2.6kg

WEIGHT WITH WIPER

3.1kg

POWER CONSUMPTION

10W

POWER CONSUMPTION WITH WIPER

16W

HEATER VOLTAGES

12V to 24V or 110V to 230V

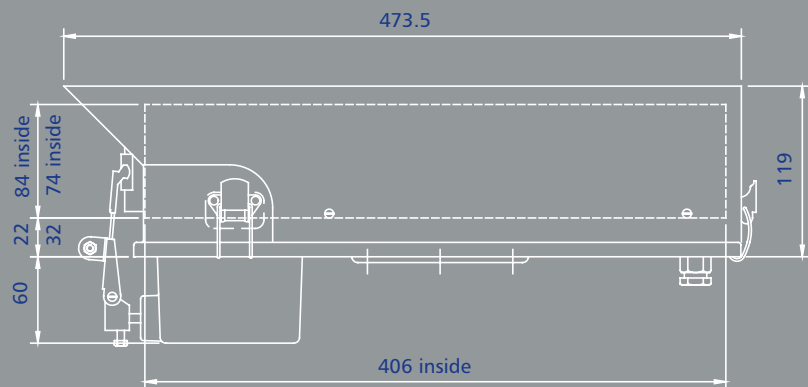
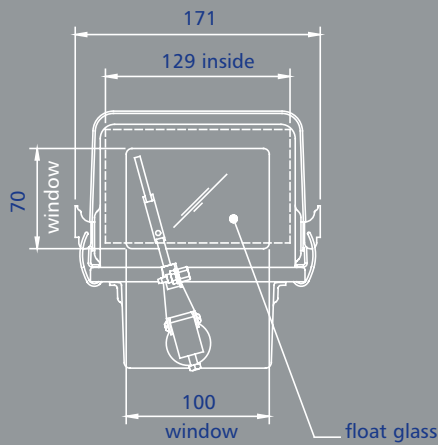

TYPE 506 CAMERA HOUSING

All Dimensions in millimetres

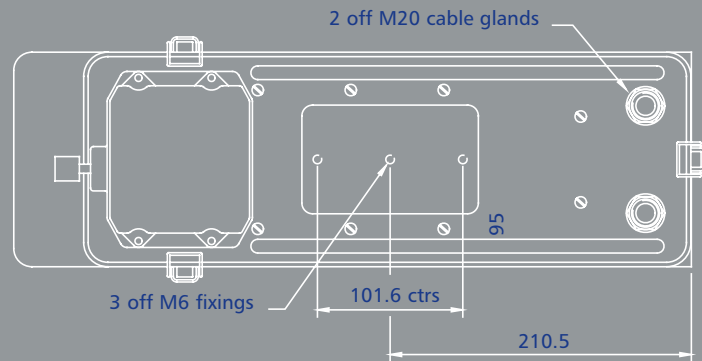

PLEASE CHECK THE WEBSITE FOR DETAILS OF COMPATIBLE PRODUCTS AND OTHER LATEST DEVELOPMENTS

FOR FURTHER INFORMATION PLEASE CONTACT

Dedicated Micros UK
Dedicated Micros USA

11 Oak Street, Swinton, Manchester M27 4FL UK Tel: +44 (0) 845 600 9500 Fax: +44 (0) 161 727 3300.
14434 Albemarle Point Place, Suite 100, Chantilly, Virginia 20151 USA Freephone: 800 864 7539
Tel: +1 703 904-7738 Fax: +1 703 904-7743 and 23456 Hawthorne Blvd. Suite 100, Torrance, CA 90505,
Tel +1 310 791-8666 Fax: +1 310 791-9877.

Dedicated Micros Germany
Dedicated Micros France
Dedicated Micros Asia
Dedicated Micros Australia
Dedicated Micros Malta
Dedicated Micros Middle East

Neckarstraße 15, 41836 Hückelhoven, Germany Tel: +49 243 352 580 Fax: +49 24 33 52 58 10.
9-13 rue du Moulinet, 75013 Paris, France Tel: +33 1 45 81 99 99, Fax: +33 1 45 81 99 89.
16 New Industrial Road, #03-03 Hudson Techno Centre, Singapore 536204 Tel : +65 62858982 Fax : +65 62858646.
5/3 Packard Avenue, Castle Hill, NSW 2154, Australia Tel: +612 9634 4211 Fax: +612 9634 4811.
UB 2, San Gwann Ind. Est., San Gwann, Malta Tel: +356 21483 673 Fax: +356 21449 170.
Building 12, Suite 302, P.O.Box 500291, Dubai Internet City, Dubai, United Arab Emirates
Tel: +971 (4) 390 1015, Fax: +971 (4) 390 8655.
Delavska cesta 24, 4208 Sencur, Slovenia Tel: +386 4 279 18 90 Fax: +386 4 279 18 91.
Joseph Chantraineplantsoen 1, 3070 Kortenberg, Belgium Tel: +32 2751 3480 Fax: +32 2751 3481.



www.dedicatedmicros.com

The manufacturer reserves the right to change the specification without notice.



All trademarks are courtesy of registered owners.
The DM logo is a trademark of Dedicated Microcomputers group Ltd.
MKT-506-D-001E