



BOSCH
Invented for life

TC9346A Series Housings Indoor/Outdoor



- ▶ For Cameras With up to 20x Zoom Lenses
- ▶ All Aluminum Construction
- ▶ Easy Installation
- ▶ Built-in Elevation Block
- ▶ Gas Spring-assisted Forward Opening Lid
- ▶ Accessories Available

The TC9346A Series Environmental Housings are constructed of aluminum, and designed to accommodate large format CCD cameras with up to 20x zoom lenses. The housing opens from the rear by releasing side mounted latches, which may be secured with a padlock. Opening is assisted by a unique gas spring that securely holds the lid when opened fully. The forward opening lid on these units allows maximum accessibility during installation and camera/lens adjustments. A unique camera sled with a built-in elevation block is provided. The block is removable and can be inverted depending on the camera/lens combination utilized.

The TC9346A Series Housings are available with a full complement of factory and field installed accessories. With heater and blower installed, these housings provide enclosure protection for camera/lens assemblies in ambient temperature range of -23°C to 49°C (-10°F to 120°F).

Installation/Configuration Notes

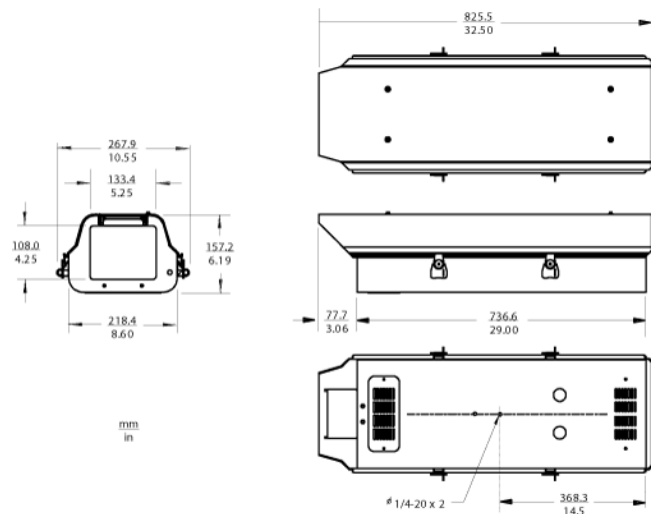

Dimensional Outline TC9346A Series Housings Outdoor

Technical Specifications

Electrical

TC9346A	
TC9346A-1	Includes Heater/Blower, 120 VAC, 60 Hz
TC9346A-2	Includes Heater/Blower, 24 VAC, 60 Hz
TC9346A-3	Includes Heater/Blower, 230 VAC, 60 Hz

Mechanical

Max Camera/Lens Size	139.7 mm x 190.5 mm x 711.2 mm (5.5 in. x 7.5 in. x 28 in.); blower kit reduces length by 165.1 mm (6.5 in.)
Cable Entry	Two glands on bottom of enclosure
Window	6.35 mm (0.25 in.) glass; 107.9 mm x 133.3 mm (4.25 in. x 5.25 in.)
Latches	Four stainless steel side-mounted latches; accepts padlock for security
Housing Mounting	Two (2) 1/4-20 tapped holes
Camera Mounting	Removable camera sled with built-in elevation block
Construction	Aluminum
Finish	Gray polyester powder coat
Dimensions	See Dimensional Outline
Weight	7.24 kg (16 lb) without heater/blower 8.15 kg (18 lb) with heater/blower

Environmental

Ambient Temperature	-23°C to 49°C (-10°F to 120°F)
Enclosure Protection	Meets NEMA-3R Standards
Product Safety	Complies with CE Regulations, UL, CSA Standards

Ordering Information

TC9346A Outdoor Housing Housing environmental heater/blower	TC9346A
--	---------

Accessories

HK57-1 Heater Assembly for TC9346A, requires O/I-PCB, 50/60 Hz, 90 W	HK57-1
HK57-2 Heater Assembly for TC9346A, requires O/I-PCB, 50/60 Hz, 50 W	HK57-2
HK57-3 Heater Assembly for TC9346A, requires O/I-PCB, 50/60 Hz, 70 W	HK57-3

Ordering Information

BK57-1 Blower Assembly for TC9346A, requires O/I-PCB, 120 VAC, 60 Hz, 15 W	BK57-1
BK57-2 Blower Assembly for TC9346A requires O/I-PCB, 24 VAC, 50/60 Hz, 10 W	BK57-2
BK57-3 Blower Assembly for TC9346A, requires O/I-PCB, 230 VAC, 50 Hz, 15 W	BK57-3
WW5729-1 Window Wiper Kit 120 VAC, 60 Hz, 15 W	WW5729-1
WW5729-2 Window Wiper Kit 24 VAC, 50/60 Hz, 15 W	WW5729-2
WW5729-3 Window Wiper Kit 230 VAC, 50 Hz, 15 W	WW5729-3
WD57-1 Window Defroster and Defogger 120 VAC, 60 Hz, 30 W	WD57-1
WD57-2 Window Defroster and Defogger 24 VAC, 50/60 Hz, 30 W	WD57-2
WD57-3 Window Defroster and Defogger 230 VAC, 50 Hz, 30 W	WD57-3
SS5729 Sunshield for TC9346A	SS5729
T157 Low Temperature Package	T157
O/I-PCB PC Board for TC9346A, required with heater, blower, or defroster	O/I-PCB

Europe, Middle East, Africa:
Bosch Security Systems B.V.
P.O. Box 80002
5600 JB Eindhoven, The Netherlands
Phone: +31 40 2577 284
Fax: +31 40 2577 330
emea.securitysystems@bosch.com
www.boschsecurity.com

Americas:
Bosch Security Systems, Inc.
130 Perinton Parkway
Fairport, New York, 14450, USA
Phone: +1 800 289 0096
Fax: +1 585 223 9180
security.sales@us.bosch.com
www.boschsecurity.us

Asia-Pacific:
Bosch Security Systems Pte Ltd
38C Jalan Pemimpin
Singapore 577180
Phone: +65 6319 3450
Fax: +65 6319 3499
apr.securitysystems@bosch.com
www.boschsecurity.com

Represented by