

**BOSCH**

Invented for life

# LTC 8x00/90 Integrated Series Allegiant Matrix/Control Systems



- ▶ **Models from 8 camera by 2 monitor to 32 camera by 6 monitor**
- ▶ **Compact single bay construction**
- ▶ **Integral alarm interface and signal distribution**
- ▶ **Powerful alarm handling features**
- ▶ **SalvoSwitching® and SatelliteSwitch® capability**
- ▶ **PC-based software package available**

The LTC 8100 Series, LTC 8200 Series, and LTC 8300 Series Allegiant® video switcher/control systems combine both switching and computer technology to provide powerful performance and unique system features for the security user. Offering full matrix switching capability, these systems can be programmed to display the video from any camera on any monitor, either manually or via independent automatic switching sequences.

These systems provide from 8 camera inputs, 2 monitor outputs to 32 camera inputs, 6 monitor outputs, 2 to 4 keyboards, 8 to 32 direct connect alarm input points, an integral signal distribution unit, and a computer interface port. A logging printer port is available in the LTC 8300 Series systems.

These systems can be programmed with up to 60 sequences which can be run independently of each other in either a forward or reverse direction.

Any of the sequences can utilize the SalvoSwitching capability where any number of system monitors may be selected to switch as a group. Using the optional LTC 8059/00 Master Control Software package or the LTC 8850/00 Graphical User Interface software package, sequences can be made to activate and deactivate automatically based upon the time of day and the day of week.

Utilizing the unit's integral signal distribution ports, connections to on-site receiver/drivers are easily made. On-site receiver/drivers provide operator control of pan, tilt, zoom; multiple pre-positions; four auxiliaries; auto-pan, and random scan. These systems also support variable speed operation and full programming functions of AutoDome® Series dome cameras.

When combined with an LTC 8016 Allegiant Bilinx™ Data Interface unit, these switcher/controllers support operations using Bilinx communication. With Bilinx, PTZ control is accomplished using a bidirectional communication protocol embedded in the video signal of Bosch Dinion™ and AutoDome® CCTV cameras. In addition, Bilinx uses the standard video cable to transmit alarm and status messages from the cameras, providing superior performance without the need for separate data transmission cables.

With their built-in alarm interface capability, an external contact closure or logic level can be used to automatically activate any camera to be displayed. Any monitor or group of monitors can be set to display cameras under alarm conditions. The base system contains three built in alarm response modes: basic, auto-build, and sequence & display. In addition to these three modes, the PC-based software packages offer the ability to combine any or all of the three standard modes within the same system. Alarm video may

be selected to reset either manually or automatically. In addition, a 16-character alarm title can be selected to appear instead of the camera title during alarm conditions.

System operation and programming is accomplished using a full-function, ergonomically designed keyboard (sold separately). Built-in operator priority levels and the ability to restrict certain operators from controlling designated functions provide maximum flexibility.

These systems include a black outlined 48-character on-screen display for time-date, camera number, camera ID (16-characters), an icon to identify controllable cameras, and monitor (12-characters) or status information. Over 235 characters are available when programming camera ID and monitor titles.

Utilizing a Windows®-based PC and the optional LTC 8059/00 Master Control Software package or LTC 8850/00 GUI software, enhanced programming and switching features can be obtained. A user-friendly spreadsheet format provides the ability to enter camera and monitor titles, program of operator names and priorities, 64 timed event actions, change system parameters, program camera sequences, install lockouts, and access the advanced alarm handling screens with speed and efficiency. The programmed information may then be transferred into the Allegiant system, stored on disk, or printed out directly from a printer connected to the PC.

The LTC 8850/00 Bosch GUI software is designed around an intuitive graphic-based interface. The GUI provides high performance programming, control and monitoring of all system functions by using on-screen icons to reflect real time status of the devices controlled by the system. The LTC 8850/00 GUI software also provides the ability to monitor system status events. System alarms, switching functions, sequence events, keyboard actions, and video loss information can be viewed in real time on the PC screen and, if desired, logged to the PC hard drive.

The software also provides the ability to enable an on-screen indicator for easy identification of controllable cameras.

The LTC 8300 Series contain a logging printer output port which accepts a standard RS 232 serial printer. This provides a permanent record of system status showing time and date for changes such as: incoming alarms, acknowledgment of alarms, sequence loading, user log-on to keyboard, transfer of system tables and sequences, video loss messages, and a power up reset message. In addition, the printer can be used to obtain a hard copy of the system's configuration tables and sequences.

These systems provide powerful macro capabilities. The macros can be activated using Allegiant Series keyboards, system time event functions, alarm activations, and via special function icons in the LTC 8850/00 GUI software.

These systems can serve as the master switcher in a SatelliteSwitch® configuration. This innovative SatelliteSwitch feature enables a single system to communicate with remotely located "Satellite" systems. Any Allegiant model can serve as a master or remote Satellite switcher. This powerful feature permits the design of a distributed matrix video switching system with control at one central location and individual control at the local sites. The main control site can view/control local cameras plus cameras located at any of the remotely distributed Satellite sites. The Satellite sites can view/control only cameras associated with their own site. When used in this type of configuration, the main system can access up to 256 cameras located anywhere in the system.

Windows is a registered trademark of Microsoft Corp.

### Certifications and Approvals

Electromagnetic Compatibility (EMC)	Complies with FCC Part 15, ICES-003, and CE regulations
Product Safety	Complies with CE regulations, UL, CSA, EN, and IEC Standards

### Installation/Configuration Notes

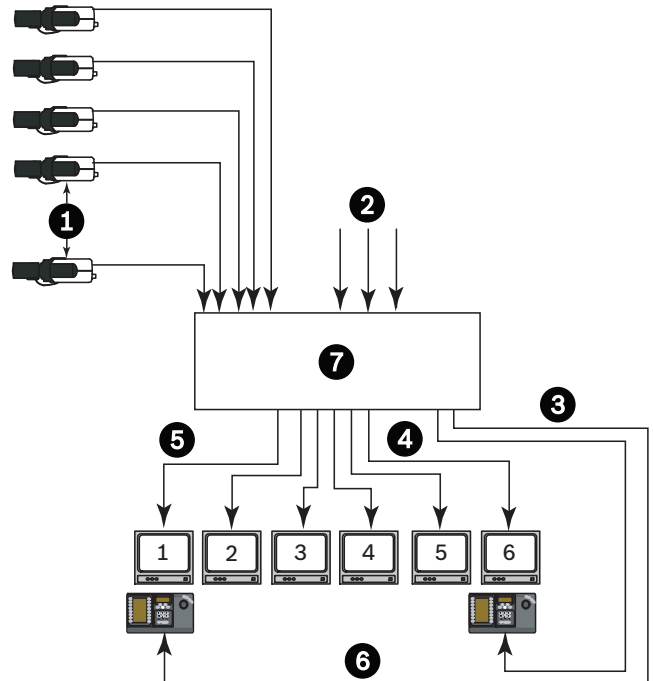

Typical LTC 8300 Series Configuration Diagram

- 1 Additional System Cameras
- 2 Up to 32 Video Inputs Maximum
- 3 3 m (10 ft) Interconnect Cable Supplied with Keyboard
- 4 Video Coax
- 5 Up to six (6) Monitor Outputs
- 6 Maximum of four (4) Allegiant Series Full Function Keyboards up to 1.5 km (5000 ft) Away Using Optional Remote Hookup Kit
- 7 LTC 8300 Series Main CPU Bay

- 8 Receiver/Driver
- 9 Up to 32 Receiver/Driver Units
- 10 Up to 1.5 km (5000 ft) Using 18 AWG Shielded Twisted Pair Cable (Belden 8786 or Equivalent)
- 11 Optional LTC 8059/00 MCS or LTC 8850/00 GUI Software Package can be Run on a Windows® based PC
- 12 Additional System Cameras
- 13 3 m (10 ft) RS-232 Interface Cable provided with Optional Software Package
- 14 LTC 8300 Series Main CPU Bay
- 15 Serial RS-232 Logging Printer Capability
- 16 3 m (10 ft) Interconnect Cable Supplied with Keyboard
- 17 Up to six (6) Monitor Outputs
- 18 Maximum of 4 Allegiant Series Full-Function Keyboards up to 1.5 km (5000 ft) Using Optional Remote Hookup Kit

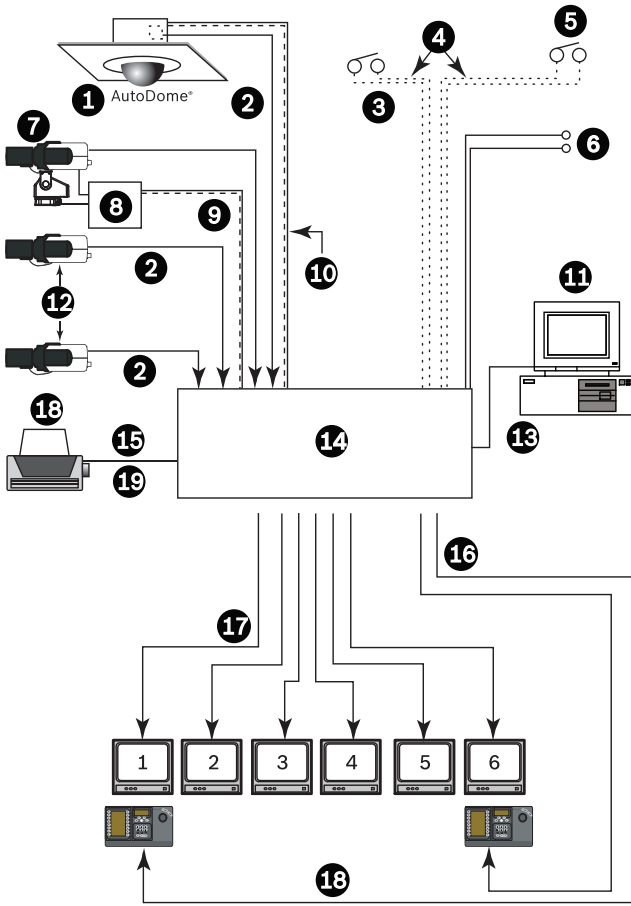

LTC 8300 Series Full Capacity Configuration Diagram  
(32 Cameras by 6 Monitors)

- 1 Typical AutoDome Camera
- 2 Video Coax
- 3 Twisted-Pair Typical
- 4 32 Separate Alarm Inputs
- 5 Contact Closure or Active Low Logic Level
- 6 Six (6) Pairs of Relay Outputs
- 7 Pan and Tilt

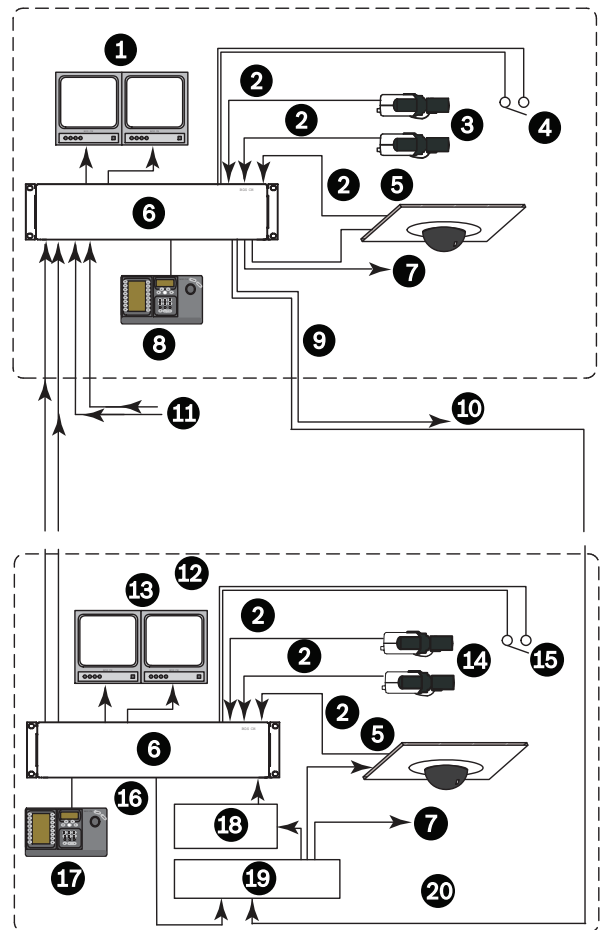

Typical Main Allegiant Control Center

- 1 Typical System Monitors (Local and/or Remote Video)
- 2 Video
- 3 Typical Fixed Cameras
- 4 Typical Alarm Input Contact to Activate Local or Satellite Cameras
- 5 Typical Controllable Camera
- 6 Typical LTC 8100, LTC 8200, or LTC 8300 Allegiant System
- 7 Bi-Phase Data Lines to All Local PTZ Camera Sites
- 8 Typical IntuiKey Keyboard
- 9 Bi-Phase Control and Satellite Switching Data
- 10 One (1) Bi-Phase Data Line to Each Remote Satellite Site
- 11 Incoming Video TRUNK Lines From All Satellite Sites
- 12 Typical Allegiant Satellite Site
- 13 Typical Local Monitors (Local Video Only)
- 14 Typical Fixed Cameras
- 15 Typical Alarm Input Contact (For Local Alarms Only)
- 16 Bi-Phase Data
- 17 IntuiKey Keyboard (PTZ Control of Local Cameras Only)
- 18 LTC 8780 Data Converter
- 19 LTC 8569 Code Merger
- 20 Bi-Phase Control + Satellite Data

## Technical Specifications

### System

#### Capacities

Model No.	LTC 8100	LTC 8200	LTC 8300
Video Inputs (Standard)	8	16	32
Video Inputs (Looping)	8	16	32
Video Inputs (Satellite)	256	256	256
Video Outputs	2	5	6
Alarm Inputs	8	16	32
Alarm Outputs	2	5	6
Bi-Phase Outputs	8	12	16
Keyboards	2	4	4
RS-232 Ports (Console)	1	1	1
RS-232 Ports (Printer)	0	0	1
Receiver/Drivers (Standard)	8	16	32
Receiver/Drivers (Satellite)	256	256	256

#### Electrical

Input Voltage Level	0.5 Vp-p to 2 Vp-p (Composite Negative Sync)
Gain	Unity ± 2% (75 Ohm terminated)
Pulse/Bar Ratio <sup>1</sup>	94% to 106%
2T Pulse K Factor <sup>1</sup>	2.5% maximum
Bar Amplitude <sup>1</sup>	96% to 106%

Field Time Waveform Distortion <sup>1</sup>	2% maximum
Line Time Waveform Distortion <sup>1</sup>	1% maximum
Short Time Waveform Distortion <sup>1</sup>	2% maximum
Video Bandwidth (-3 dB) <sup>2</sup>	22 MHz
Frequency Response <sup>2</sup>	± 1.0 dB to 10.5 MHz
Signal-to-Noise <sup>1</sup>	60 dB at 3.58 MHz unweighted minimum (Typical at 3.58 MHz)
Crosstalk (Adjacent Channel)	-52 dB at 3.58 MHz
Differential Gain <sup>1</sup>	2% maximum
Differential Phase <sup>1</sup>	1.3° maximum
Chrominance Luminance Gain <sup>1</sup>	96% to 104%
Chrominance Nonlinear Phase <sup>1</sup>	2° maximum
Luminance Nonlinearity <sup>1</sup>	4% maximum
Switching	Crosspoint matrix
DC Output	0 V

<sup>1</sup> Meets EIA/TIA - 250C Medium Haul Standard.

<sup>2</sup> One camera to one monitor.

#### Environmental

Operating Temperature	4°C to 55°C (40°F to 131°F)
Storage Temperature	-40°C to 60°C (-40°F to 140°F)
Altitude	4500 m (15,000 ft)
Humidity	0% to 95% relative, non-condensing

#### LTC 8100, LTC 8200, LTC 8300 Series Bay

#### Electrical

Model No.	Voltage Range	Nominal Power <sup>2</sup>
LTC 8100/90	108 to 253 VAC, 50/60 Hz	15 W
LTC 8200/90	108 to 253 VAC, 50/60 Hz	17 W
LTC 8300/90	108 to 253 VAC, 50/60 Hz	18 W

<sup>2</sup> Power at rated voltage fully loaded.

#### Connectors

Video Inputs and Monitor Outputs	BNC
----------------------------------	-----

#### Looping Video Connections

LTC 8100 Series	8 BNC
LTC 8200 Series	One 34-pin ribbon connector used with the LTC 8808/00 video interconnect panel (not included)
LTC 8300 Series	Two 34-pin ribbon connectors used with the LTC 8808/00 video interconnect panel (not included)

**External Accessory Interfaces**

CONSOLE	RS-232 port for external PC or control interface (default = 19,200 baud) 9-pin D-type connector
ALARMS	Inputs use removable screw terminal connectors. Relay outputs provide alarm output connections. (Contact rating = 1.5 A at 30 VDC)
PRINTER (LTC 8300 Series only)	RS-232 port for system logging printer (Default = 19,200 baud) 9-pin D-type connector
BIPHASE OUT	Multiple ports provide receiver/driver connections when used in a daisy chain configuration. Removable screw terminal connector blocks.
KEYBOARDS	6-pin RS-485 ports for Allegiant keyboard use

**Mechanical**

Construction	Steel chassis with sheet metal cover and plastic bezel
Finish	Charcoal

**Dimensions**

LTC 8100, LTC 8200 Series (H x D x H)	440 x 305 x 40 mm (17.3 x 12 x 1.7 in.)
LTC 8300 Series (H x D x H)	440 x 305 x 89 mm (17.3 x 12 x 3.5 in.)

**Weight**

<ul style="list-style-type: none"> <li>LTC 8100, LTC 8200 Series</li> </ul>	4 kg (8.8 lb)
<ul style="list-style-type: none"> <li>LTC 8300 Series</li> </ul>	4.8 kg (10.7 lb)
Rack Mount (Integral)	Brackets for mounting one unit in a 48 cm (19 in.) EIA rack
<ul style="list-style-type: none"> <li>LTC 8100, LTC 8200 Series</li> </ul>	One (1) standard rack unit high
<ul style="list-style-type: none"> <li>LTC 8300 Series</li> </ul>	Two (2) standard rack units high

**Accessories**

The Allegiant accessory products provide many optional features to the base Allegiant switching systems. Accessory products include keyboards, keyboard extension kits, Allegiant Bilinx Data Interface unit, receiver/driver units, switcher/followers, and code merger units. All accessory products are designed to be installer-friendly and compatible throughout the Allegiant series systems. See the Allegiant Accessories datasheet.

**Ordering Information**

<b>LTC 8100/90 Allegiant Matrix Switcher</b> 8 camera inputs/2 monitor outputs, incl. Bi-phase outputs and alarm contacts, 108 to 253 VAC, 50/60 Hz	<b>LTC 8100/90</b>
<b>LTC 8200/90 Allegiant Matrix Switcher</b> 16 camera inputs/5 monitor outputs, incl. Bi-phase outputs and alarm contacts, 108 to 253 VAC, 50/60 Hz	<b>LTC 8200/90</b>
<b>LTC 8300/90 Allegiant Matrix Switcher</b> 32 camera inputs/6 monitor outputs, incl. Bi-phase outputs and alarm contacts, 108 to 253 VAC, 50/60 Hz	<b>LTC 8300/90</b>

**Software Options**

<b>SFT-VASA Hybrid IP - Analog/Matrix Video over IP Integration Software</b>	<b>SFT-VASA</b>
--	-----------------

**Americas:**

Bosch Security Systems, Inc.  
130 Perinton Parkway  
Fairport, New York, 14450, USA  
Phone: +1 800 289 0096  
Fax: +1 585 223 9180  
security.sales@us.bosch.com  
www.boschsecurity.us

**Europe, Middle East, Africa:**

Bosch Security Systems B.V.  
P.O. Box 80002  
5600 JB Eindhoven, The Netherlands  
Phone: +31 40 2577 284  
Fax: +31 40 2577 330  
emea.securitysystems@bosch.com  
www.boschsecurity.com

**Asia-Pacific:**

Bosch Security Systems Pte Ltd  
38C Jalan Pemimpin  
Singapore 577180  
Phone: +65 6319 3450  
Fax: +65 6319 3499  
apr.securitysystems@bosch.com  
www.boschsecurity.com

**Represented by**