

SAFEGUARDS AND WARNINGS

⚠ WARNING

Installation and servicing is only to be carried out by suitably qualified and experienced personnel

This product is designed for use in general purpose CCTV applications and has no other purpose

This product is designed to operate in a class 2 indoor general environment and must not be installed where exposed to rain or moisture.

This product must be powered from a class 2 isolated power source as supplied

CERTIFICATIONS

This product meets the requirements of the following standards:

Electromagnetic Compatibility

EN55022:1995 limits and methods of measurement of radio disturbance characteristics of information technology

EN50082-1:1992 Electromagnetic compatibility- Generic Immunity standard

Comprising:

IEC 801-2:1991 Electrostatic discharge

IEC 801-3:1984 Radiated electromagnetic fields

IEC 801-4:1988 Fast transient bursts

Safety

EN 60950: 1992 Safety of information technology equipment, including electrical business equipment

DECLARATIONS

The manufacturer declares that the DAX unit supplied with this manual, is compliant with the EMC directive 89/336 EEC and the low voltage directive 73/23/EEC and 93/68/EEC

DESCRIPTION

The DAX/PELCO converts Baxall coaxial telemetry into Dome telemetry. It connects between your transmitter and dome camera in the coaxial line as shown below. The DAXPELCO requires a +12 VDC or 24 VAC class 2 isolated power supply.

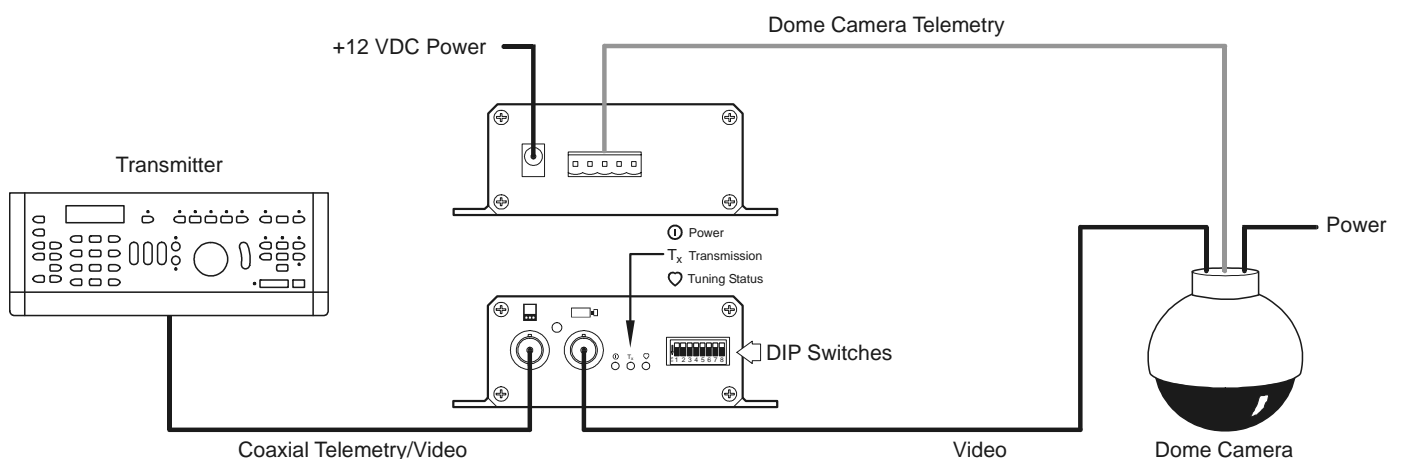

DAX/PEL Installation

SWITCH SETTINGS

Your DAX/PELCO is compatible with dome cameras that support the Pelco 'D' protocol. DIPswitches located on the front of the DAX/PELCO are used to set the mode of autopan as shown below.

Switch 1 ON: Disables the auto iris timer	Switch 1 OFF: Enables the auto iris timer
Switch 2 ON: Disables the auto focus timer	Switch 2 OFF: Enables the auto focus timer
Switch 3 ON: Disables the focus at pan/tilt stop	Switch 3 OFF: Enables the focus at pan/tilt stop
Switch 7 ON: Extended preset mode enabled.	Switch 7 OFF: Use WIPE key to access presets 9-16 (see below)

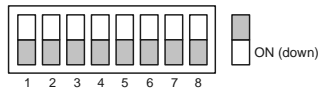
**STORING AND RECALLING PRESETS**

To store a preset using a ZTX6:

1. Press the Function (F) key
2. Enter the preset number*.
3. Press the Preset (X) key.

To store a preset using a ZMX:

1. Press the Function (F) key and then the Preset (X) key.
2. Enter the preset number*.

To recall a preset using a ZTX6:

1. Enter the preset number*.
2. Press the Preset (X) key.

To recall a preset using a ZMX:

1. Press the Preset (X) key.
2. Enter the preset number*.

* Preset numbers can be between 1 and 16. To enter the number for a preset that is between 1 and 8, make sure the WIPE (W) key is set to OFF and use the numbers 1 to 8 on the keyboard. To enter the number for a preset that is between 9 and 16, make sure the WIPE (W) key is set to ON and use the numbers 1 to 8 on the keyboard.

EXTENDED FEATURES**Menu Mode**

Use the following procedure to access the camera's menu mode:

1. On the transmitter, set POWER/AUX1 (P) to ON.
2. On the transmitter, set WIPE/AUX6 (W) to ON.
3. Select any preset to activate the menu.
4. Use the tilt controls to move the menu cursor up or down. Use the pan controls to change menu values.
5. The Iris Open key operates as the menu selection key.
6. The Iris Close key operates as the menu cancel key.

INSTALLATION

All video is 1 V pk-pk composite via 75 ohm video coaxial cable and BNC connectors. The connections to your DAX/PELCO are shown on the case and in the schematic overleaf.

- Connect the +12 VDC and the Dome Camera's RS 485 extension lead to the connectors on the Interface Unit according to the schematic.
- Connect the Interface Module to your transmitter and to your dome camera according to the schematic.
- The Camera ID should be set to 1 using the 'D' protocol.

SPECIFICATION

Inputs : Baxall coaxial telemetry as defined by the Baxall coaxial telemetry specification, +12 VDC or 24 VAC

Output : Dome Camera telemetry.

Power : nom. +12 VDC (min. 8.0 VDC max. 24 VDC) class 2 isolated, 50mA max. (0.6 Watts); 24 VAC.

Power Supply : 230 VAC to +12 VDC class 2. Max 200mA.

Dimensions : 115 x 107 x 37 mm. (WxDxH)

Temperature limits : Only use this product between the temperatures of -10° and +40° C.

CONNECTORS

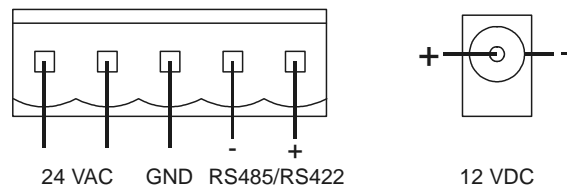

MOUNTING

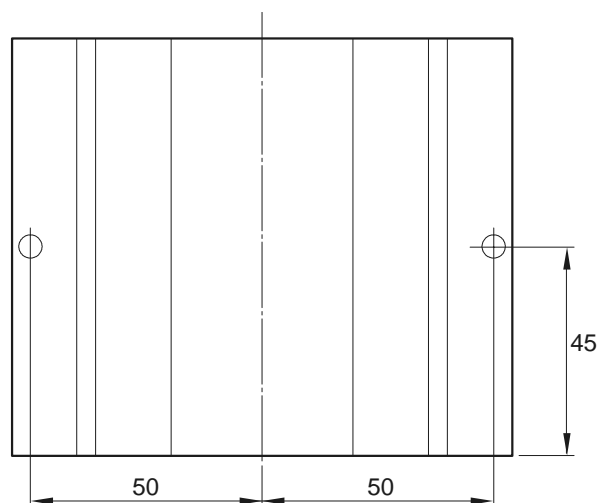

Baxall Limited, Stockport, England. Visit our Web site: <http://www.baxall.com>

Baxall Limited reserve the right to make changes to the product and specification of the product without prior notice to the customer.