

Minivandal Day/Night IR COLOR DOME CAMERA

VD70CSIR Series

- VD70CS(X) - 36IR 400TVL
- VD70CSHR(X) - 36IR 500TVL

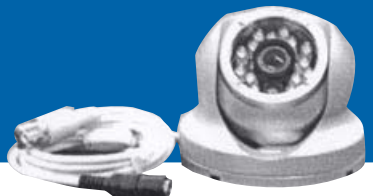

Dear Customers!

By selecting this product, you have decided to use a professional device that guarantees highest quality and reliability. We would like to thank you very much for your confidence and kindly ask you to read the following instructions carefully before installation and operation in order to take full advantage of all quality features regarding this product.

CAUTION
RISK OF ELECTRIC SHOCK
DO NOT OPEN

CAUTION
TO REDUCE THE RISK OF ELECTRIC SHOCK,
DO NOT REMOVE THE COVER (OR BACK),
NO USER SERVICEABLE PARTS INSIDE.
REFER SERVICING TO QUALIFIED PERSONNEL.

The lightning flash with an arrowhead symbol, within an equilateral triangle is intended to alert the user to the presence of uninsulated dangerous voltage within the product's enclosure that may be of sufficient magnitude to constitute a risk of electric shock to persons.

The exclamation point within an equilateral triangle is intended to alert the user to the presence of important operating and maintenance (servicing) instructions in the literature accompanying the appliance.

INFORMATION

This equipment has been tested and found to comply with limits for a Class A digital device, pursuant to part 15 of the FCC Rules. These limits are designed to provide reasonable protection against harmful interference when the equipment is operated in a commercial environment. This equipment generates, uses, and can radiate radio frequency energy and, if not installed and used in accordance with the instruction manual, may cause harmful interference to radio communications. Operation of this equipment in a residential area is likely to cause harmful interference in which case the user will be required to correct the interference at his own expense.

WARNING

Changes or modifications not expressly approved by the manufacturer could void the user's authority to operate the equipment.

CAUTION - To prevent electric shock and risk of the fire hazards:

- Do NOT use power source other than that specified.
- Do NOT expose this appliance to rain or moisture.

The installation should be conducted by qualified service personnel and should conform to all local codes.

Special features of the model

Extremely high resolution 400TVL(Med-Res) / 500TVL(Hi-Res)

This camera offers an extremely high resolution of 400TVL(Med-Res) / 500TVL(Hi-Res) at daytime in Color image and 420TVL(Med-Res) / 560TVL(Hi-Res) at nighttime in B/W image.

True Day & Night

The image is automatically converted from Color to B/W at 4-5Lux darkness. This function maintains the picture quality at daytime true Color and noiseless clear B/W image at nighttime enhancing the sensitivity and resolution up to 420TVL(Med-Res) / 560TVL(Hi-Res)

Excellent sensitivity

By using a Sony Super HAD, the camera offers an excellent sensitivity of 0.2lux/F1.2 (0.1Lux BW) or lower illumination w/o LED and "0" Lux with LED on.

Perfect tri-axis

This device proves the PERFECT tri-axis angle adjustments so that the image be always upright at any position of the camera's installation. The tilt angle comes down to 90 degree allowing the camera to view and record the object at the center of the screen.

Warnings & precautions

- Please read the manual carefully before the installation in order to set up the camera correctly and to achieve the best picture quality.
- Follow these safety instructions. This will help prevent possible damages from improper use.
- Please keep the manual in good condition for your future reference and service application.
- Installation and services should only be carried out by an authorized personnel according to local safety regulations.
- Repairs and adjustments of the camera should be conducted by an authorized personnel.
- If any liquid or solid matter gets into the housing, immediately disconnect the camera from powersupply and have it checked by your authorized dealer before reusing it.
- Avoid installing the camera in extremely hot or cold places.
- If you are not a certified person, never try to dismantle the camera. To avoid electric shock, never remove the screws or covers. There are no parts inside that need maintenance by the user. Qualified personnel should carry out all maintenance.
- Please give a special attention to keep the unit from dangerous drop or external shock during the process of transportation or handling.
- Never try to touch the camera in wet hand. It may cause an electric shock.

Note!

- Make sure to use a regulated 12VDC power source.
- Check the power with the power tester to make sure if the power supply gives an exact 12VDC regulation. Even sometimes, UL marked power supply unit generates unregulated power causing the camera to burn in many cases.

Package

1. High resolution Color CCD Camera
2. User's manual
3. Mounting material
4. Connection cable

Dimension (mm)

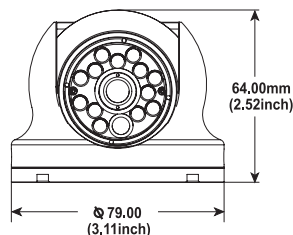

Assembly overview

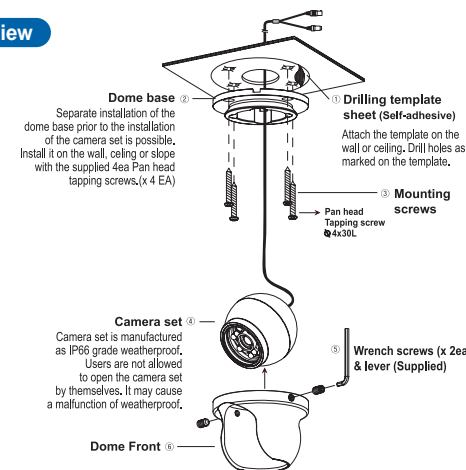

Installation

- Installation and services should only be carried out by an authorized personnel according to local safety regulations.
- Should liquid or solid matter gets into the housing, disconnect the camera immediately from the power source and have it checked by your authorized dealer before reusing it.
- Keep an adequate distance from direct heat sources.
- Avoid installing the camera at a place of high humidity.
- Avoid installing the camera at a place exposed to gas or oil.
- Keep the top glass of the lens always clear in order to obtain the best picture quality all the time. Be careful not to stain the lens and the outer glass by fingerprints.
- Do not point the camera toward artificial lightings, the sun, the sky or to the direction of a window. The best picture quality will be achieved if both camera and lighting point to the area you want to record.
- Do not expose the camera to radioactivity. It causes a serious damage on the CCD.
- Do not put objects inside the unit. Make sure that no metal objects or flammable substances get into the camera. It could cause fire, short-circuits or damages.
- Install away from electric or magnetic fields.

1. Overview of 3 directional adjustments

This unit provides an advanced way of mechanical adjustment of the camera angle that can freely position to all directions from ceiling, wall or slope mounting. Especially, noticeable points are Vertical angle that can be tilt down to 90 degree and the Rotation adjustment that can correct the image to be upright condition when the dome camera is installed on the wall or on the slope.

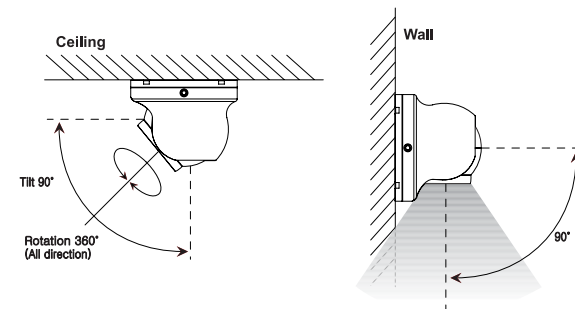

<Perfect 3-AXIS adjustments>

- Vertical angle can be tilt down to its maximum 90 degree. (Tilt = 90°)
- Horizontal angle is adjustable to its maximum 360 degree. (Horizontal = 360°)
- Rotation angle is adjustable to its maximum 180 degree. (Rotation = 180°)

Please lock the dome with the lever strong enough after adjustments so that the camera's angle withstands its direction firmly against vibration or external shock.

Caution!

- Please make sure that the surface of the lens and the dome cover always stay clear.
- When these parts are contaminated, clean them very carefully with soft cloth.
- Even a small scratch on these parts results in the picture blooming or reflection.

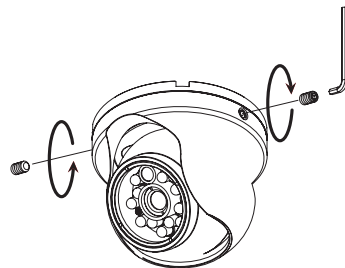

2. Video Monitor

Connect Video cable with BNC-male connector to the monitor.

Impedance alliance in the system connection.

Make sure to connect the cable with the power off.
Please locate the impedance switch of each equipment as instructed.

- Locate the switch to Hi-z position for the interim equipments.
- Locate the switch to 75 Ω for the last equipment.

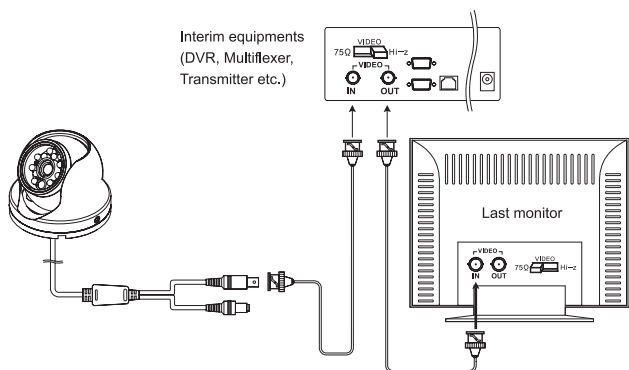

3. Power

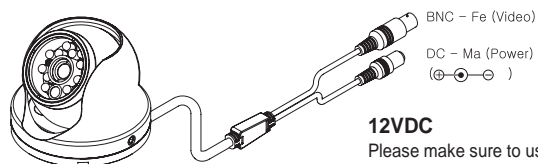

12VDC
Please make sure to use a UL/CE approved and 12VDC regulated power supply.

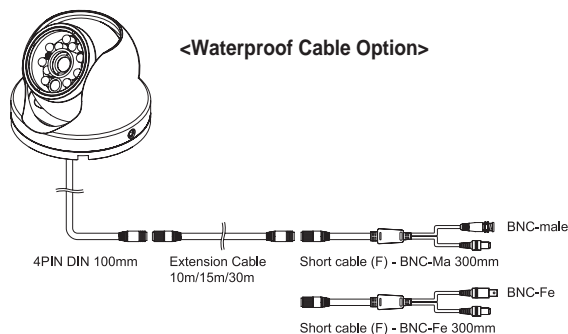

Trouble shooting

Before sending the camera out for repair, check the items below. If the camera persists after checking these items, contact your service center.

Nothing appears on the screen.	<ul style="list-style-type: none"> • Please check the power connection. • Please check the video signal line connection.
The video image is not clear.	<ul style="list-style-type: none"> • Please check if the lens or the outer glass is clean. - Dirt or fingerprints on the lens can affect the image blooming or reflection. Gently wipe any dirt or fingerprints off the lens or the glass with a soft cloth. • Please check and adjust contrast feature of the monitor • Please check if the camera is exposed directly toward a bright light, sunlight, or sun light reflecting area. • Please move the camera's position in this case.
The screen is dark.	<ul style="list-style-type: none"> • Please check and adjust contrast feature of the monitor • If there is any interim equipment, set the 75 Ω position properly and check the terminals. • Please check if the power supply is within the specification. - When the cable connection requires a long distance, there may need a higher power supply or an additional power/video amplification.
The camera's surface is too hot and black stripes appear on the screen.	<ul style="list-style-type: none"> • Please check if the power supply is regulated and is within the standard requirement of the product.
The screen is flickering.	<ul style="list-style-type: none"> • Please check if the camera is facing directly toward sunlight or fluorescent light.
IR beam is weak	<ul style="list-style-type: none"> • Check if the distance of the cable installation is too long or if the cable is not UL standard. Using a lower grade cable or long distance cable installation can cause a serious voltage drop. Please check the voltage output level of the cable and change the power source in this case. Make a special care not to supply too much power over the camera as well.

Specification

ITEM		VD70CS(X)-36IR	VD70CSHR(X)-36IR
Power	Input voltage	12VDC	
	Operating current	200mA	
CCD	Sensor	1/3" Sony Super HAD CCD (option : 1/3" Sony Ex-view HAD CCD)	
	Effective Pixels	NTSC : 512(H) X 492(V)	768(H) X 494(V)
		PAL : 500(H) X 582(V)	752(H) X 582(V)
SYNC	Scanning system	2:1 Interlace	
	Synchronization	Internal	
Electrical	Resolution (C: Color / B: B/W)	NTSC : 400TVL (C) / 420TVL (B)	NTSC : 500TVL (C) / 560TVL (B)
		PAL : 380TVL (C) / 400TVL (B)	PAL : 480TVL (C) / 540TVL (B)
	Video output	1.0Vp-p	
	S/N Ratio	50 dB (AGC Off)	
	Min. Illumination	0.2Lux / F2.0 (IR Off) (option : 0.1 Lux / F2.0 (IR off))	
		0 Lux / F2.0 (IR On)	
	Gain control	Auto	
	White balance	Auto	
Shutter speed	1/60 (NTSC) ~ 1/120,000 per sec.		
	1/50 (PAL) ~ 1/100,000 per sec.		
Lens	Monofocal	IR corrective 3.6mm / F2.0 - Standard	
		4.3mm, 6mm, 8mm - Optionable	
Day/Night	Image conversion	Color at day and Real B/W image at night	
	Infra-red	850nm-30°IR x 14ea - Standard	
940nm-30°IR x 14ea - Option			
Environmental	Weatherproof	IP66	
	Operating temp.	- 20°C ~ +50°C (- 4°F ~ +122°F)	
	Storage temp.	- 40°C ~ +70°C (- 40°F ~ +158°F)	
Physical	Dimension	φ 79 x 64 mm (φ 3.11" x 2.52")	
	Weight	Approx. 300g	

*Specifications are subject to change without prior notice.