



## ScramblePad<sup>®</sup> ScrambleProx<sup>™</sup>

*Hirsch's ScramblePad provides a high security solution to access control. It eliminates the cost and maintenance of cards or other physical credentials. ScramblePad provides a local means to control a wide variety of functions in the facility. The standard ScramblePad now includes Hirsch's MATCH<sup>™</sup> functionality, which interfaces to conventional readers and upgrades the readers to dual technology. ScrambleProx consists of a ScramblePad with a built-in proximity reader for a variety of card plus code applications. Both are used with a Hirsch controller.*

### Features

- Scrambling Display
- Horizontal & Vertical Viewing Restrictors
- Multi-function Operator Interface
  - Access Control
  - Programmer's Terminal
  - Alarm & Relay Control
  - Override HVAC, Lighting, etc.
- Immediate Availability of Codes
  - No Waiting for Cards
  - Instant Authorizations
- Codes Are Free, Cards Cost Money
- Dual Technology
  - Support 1 or 2 Readers
  - AutoSTART Scrambling Display
- ScrambleProx
  - Built-in Proximity Reader
  - Low Profile, Small Footprint
  - High Security
- Microprocessor Based
- Mathematical Digitizing Algorithm
  - High Security Transmission
  - Eliminates Facility Codes

- 3 to 8 Digit Codes
  - More Than 111 Million Random Code Possibilities
- Digital Transmission
  - Long Wiring Runs
  - Multi-drop Connections
- Audible Feedback

### Description

The Hirsch ScramblePad is an access control reader delivering the additional benefits of remote operator control and tenant override functions. The ScramblePad provides a very high security approach to access because the digits are randomly scrambled each time the START button is pressed. A bystander cannot acquire the code by seeing which buttons were pressed (pattern recognition). No wear pattern develops on the buttons. Horizontal and vertical light guides narrow the viewing field so only one person directly in front of the keypad can see the display.

The ScramblePad uses a Personal Identification Number (PIN code) of 3 to 8 digits. The system administrator can assign the digits or let the system randomly generate them. A different number of digits (code length) may be concurrently assigned to different groups for access control or other custom control functions.

Use of a memorized credential means that an individual cannot leave the credential at home, as often happens with cards. Nor can another person copy the credential without the owner's knowledge. Since the credential is so secure and traceable to its owner, it is not likely to be loaned out, a constant risk with card technologies. Thus each user is held accountable for his/her individual code use.

The MATCH function (a standard feature of the DS47L ScramblePad) provides a universal reader interface for analog or pulsed signal readers.

The on-board 5VDC power source powers most readers. Used with a conventional reader, the MATCH function converts the card's raw code into a MATCH code, the security code used by a Hirsch DIGI\*TRAC™ controller — without a need to decipher. This allows existing card access systems to be upgraded and made more intelligent without replacing existing cards and readers. Hirsch recommends existing cards be sent to Hirsch for evaluation.

The dual technology feature protects against lost or stolen cards by requiring a user to enter a code after presenting a card. When dual technology is used, the ScramblePad may be configured to operate card only, code only or card plus code based on time of day or a specific individual.

### Remote Control by Extension Digits

The use of “extension digits” allows authorized users to issue up to 27 unique command functions.

Examples include:

- Door Unlock/Relock
- Mask/Unmask Alarms
- Arm/Disarm Security Systems
- After-Hours HVAC or Lighting Activation
- Remote Control of Mechanical or Electrical systems
- Elevator Floor Requests
- Other Custom Control Sequences

Any code use provides an audit trail, identifying who issued each command. The same ScramblePad used for access control can also issue function commands.

### High Security Communication Path

The ScramblePad uses its own micro-processor intelligence to digitize the code for transmission to a Hirsch

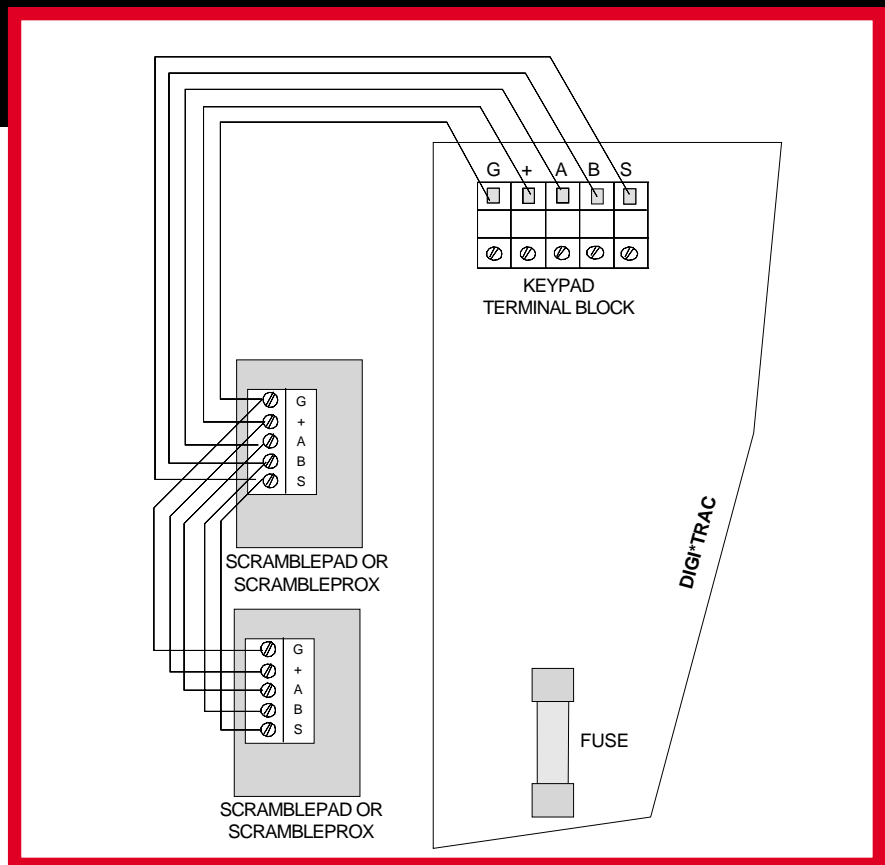

Typical Controller-to-ScramblePad/ScrambleProx Wiring Diagram

DIGI\*TRAC controller. Digital transmission permits longer wiring runs between ScramblePad and controller than are normally available with conventional technologies. The communication path also allows for multi-drop connections. This enables entrance and exit keypads, as well as dual technology applications, on the same cable.

### Programmer's Terminal

The ScramblePad also functions as a programming terminal for Hirsch DIGI\*TRAC controllers. This provides a complete, low-cost access control system with no need for a PC. Programming functions supported include:

- Add/Delete User Access Codes
- Assign Unlock/Relock Codes
- Assign Mask/Unmask Codes
- Add/Delete Relay Control Codes (e.g., for elevators, HVAC, lighting)
- Add/Delete Time Schedules & Holidays

## Specifications

### Attributes

Note: the ScramblePad and ScrambleProx are designed to operate with a Hirsch controller.

- User Codes: 3 to 8 digits (user definable or randomly generated) plus duress
- Code Tamper Alarm
- Display Pattern:
  - Secure Mode: Scrambled
  - Programming Mode: Normal, telephone keypad position
- Reader Types & Data Formats Accepted
  - ABA Magnetic Stripe
  - Wiegand (26- to 55-Bit Format)
  - Proximity
  - Bar Code
  - Touch Memory
  - Barium Ferrite
  - RF (Radio Frequency)
  - Biometric

### Electrical

- Wiring Type: 2 pair, stranded, twisted, overall shield
- Wiring Distance: Refer to controller specifications

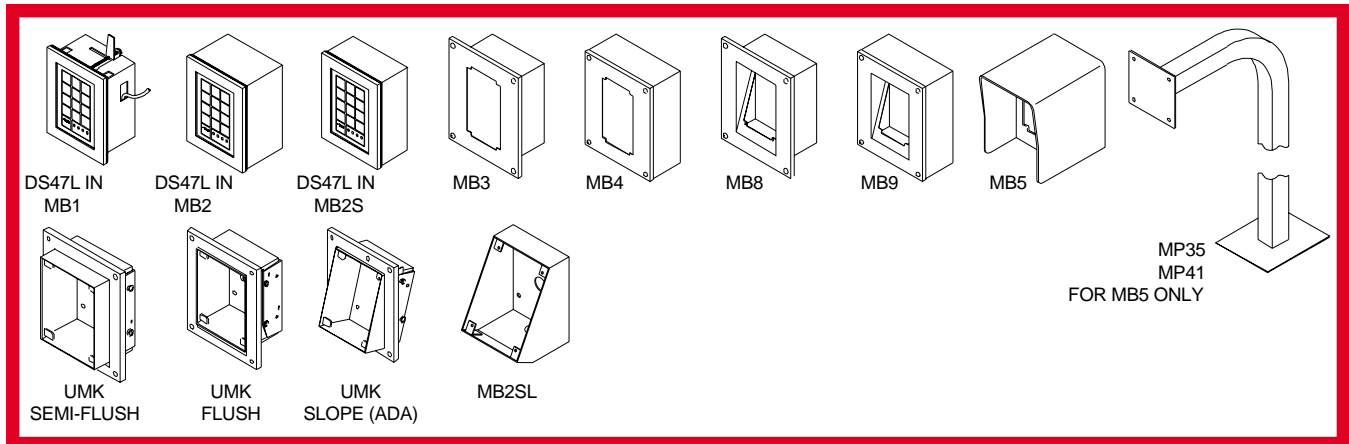

### ScramblePad/ScrambleProx Mounting Accessories

- Supervision: Digital From Controller
- Wiring To Reader: Refer to reader specifications
- Display: 7 segment
  - DS47L: Red LED
  - DS47L-HI: White incandescent
- Annunciation:
  - Audible: 7 tone prompt on pressing START, and 1 tone feedback for each button.
  - Visual: 4 LEDs: Red, green, yellow, yellow
- Operating Power For DS47L:
  - 40 mA @ 24VDC when non-illuminated
  - 125 mA @ 24VDC when illuminated
  - 60 mA @ 12VDC when non-illuminated
  - 215 mA @ 12VDC when illuminated
- Operating Power For DS47L-HI
  - 40 mA @ 24VDC when non-illuminated
  - 250 mA @ 24VDC when illuminated
- Operating Power For DS47L-SPX
  - 50 mA @ 24VDC when non-illuminated
  - 135 mA @ 24VDC when illuminated
- Operating Power For DS4L-SPX-HI
  - 50 mA @ 24VDC when non-illuminated

- 250 mA @ 24VDC when illuminated
- Reader Power: 2 terminals
  - 250mA @ 5VDC
- Operating Power For SPSH-1
  - 600 mA @ 24VDC
- ScrambleProx Card Read Range:
  - 1.4 to 2.0 in. (3.5 to 5.0 cm)

### Physical

- Physical Tamper Alarm
- One-Piece Molded Keyface
- Recommended Mounting Height, AFF to centerline:
  - Standard mounting height: 58"
  - ADA mounting height: 48"
  - Requires appropriate Hirsch mounting box
  - Follow local codes
- Dimensions:
  - Face: 5.75"H x 4.37"W (14.6 cm x 11.11 cm)
  - Body: 4.5"H x 3.5"W x 1.75"D (11.43 cm x 8.89 cm x 4.28 cm)
- Shipping Weight: 2 lb. (.90 kg)
- Operating Temperature Range:
  - 0° to 140°F (-20° to 60°C)
- Relative Humidity: 0 to 90%, non-condensing
- Viewing Restriction (Display Angle):
  - DS47L ± 4° horizontal; ± 26° vertical
  - DS47L-HI ± 20° horizontal; ± 26° vertical

### Accessories

- MB1 Flush Mounting Box
- MB2 Surface Mounting Box
- MB2S Shallow Version of MB2
- MB2SL Sloped Surface Mounting Box
- MB3 Heavy Duty Flush Mounting Box
- MB4 Heavy Duty Surface Mounting Box
- MB5 Exterior, Heavy Duty Surface Mounting Box
- MB8 Heavy Duty Flush Mounting Box, Slope Front Face Plate (ADA)
- MB9 Heavy Duty Surface Mounting Box, Slope Front Face Plate (ADA)
- MB/FFP Flat Faceplate
- MB/SFP Slope Front Faceplate
- MB/SWS Shallow Wall, Semi-flush Spacer Ring
- MP35 Mounting Post, 35" (88.9 cm) for curb mounting
- MP41 Mounting Post, 41" (104.1 cm) for ground level mounting
- UMK Universal Mounting Kit (requires MB2)
- SPSH-1 ScramblePad Space Heater Assembly, for use with MB5, where temperatures drop below freezing

### Listings & Approvals

- UL 294 Access Control Systems Units
- C-UL Signal Appliances

# Systems With Integrity

## Ordering Information

Model #	Description	Comments
DS47L	ScramblePad (With MATCH Capability)	Scrambling Display & Viewing Restriction
DS47L-HI	ScramblePad (With MATCH Capability) — High Intensity Display	For high ambient light environments. Weatherized
DS47L-SPX	ScrambleProx	Dual Technology Readers. ScramblePad with built-in Proximity Reader. Uses HID Cards
DS47L-SPX-HI	ScrambleProx — High Intensity Display	For high ambient light environments. Weatherized. Uses HID Cards
DS47L-SPX-M	ScrambleProx	Dual Technology Readers. ScramblePad with built-in Proximity Reader. Uses Motorola/Indala Cards
DS47L-SPX-M-HI	ScrambleProx — High Intensity Display	For high ambient light environments. Weatherized. Uses Motorola/Indala Cards

NOTE: The DS47L supports dual technology entry, card reader exit. For dual technology entry, dual technology exit use two DS47L units. (Readers not included)

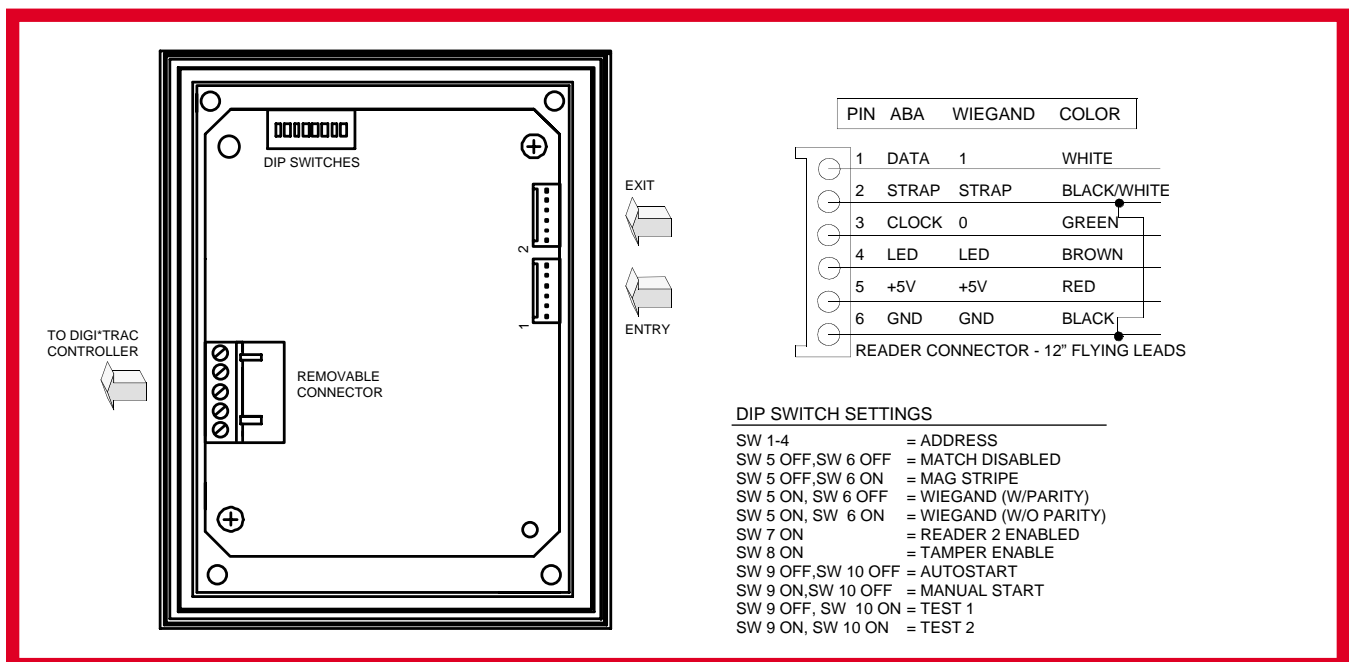

Back Of ScramblePad/ScrambleProx.



Specifications are subject to change without notice.

### Global Headquarters

1900 Carnegie Ave., Bldg. B Santa Ana, CA 92705 USA  
949-250-8888 Fax 949-250-7372

[www.hirschelectronics.com](http://www.hirschelectronics.com)

PDS001-502