

AGB600

Audio glass break detector

- Operating radius up to 8.5m
- Signal analysis based on a neuronal network
- Detector can be tested by using the glass break simulator GT2
- Acoustic function check of the whole covered area
- Optimised for single or multiple gazed objects fitted with simple window glass

To do its unique signal analysis based on a neuronal network, the AGB600 is immune to false alarms by maximum detection reliability. That fact makes it ideally suited for use in a wide range of applications, including commercial and residential premises, public buildings and similar locations requiring stringent security.

Outstanding false alarms immunity and fast and simple installation

- A comprehensive protection concept makes the detector insensitive to environmental disturbances such as traffic, ringing, whistling, sources of ultrasound and electro-magnetic interference.
- Thanks to its small and unobtrusive housing, the detector can be mounted onto walls and ceiling. The AGB600 is equipped with two settings for an accurate adjustment to the application and environment.
- With the help of the acoustic glass break simulator GT2, the whole operating radius (up to 8.5m) is completely controllably.

Coverage area and dimensions

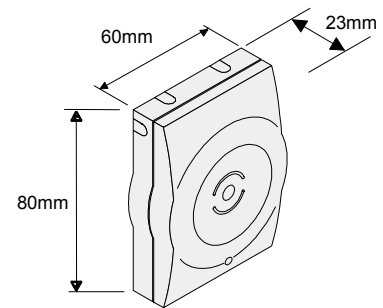
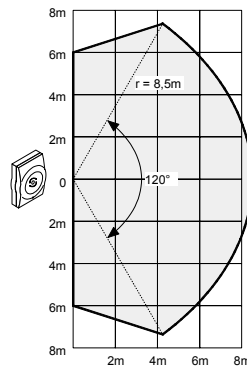
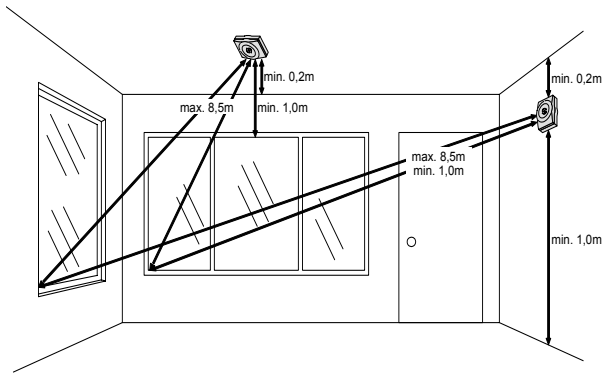

Technical data

Supply voltage	8.0 ... 16.0V _{DC} (12V nom.)
- Voltage monitoring	Alarm at < 3.5V ± 0.5V
Current consumption (at 8 ... 16V _{DC})	
- Quiescent	3.2mA
- Maximum (with LED)	8mA
Alarm Output	
- Semiconductor relay (opens on alarm)	30V _{DC} / 100mA / R _i < 40Ω ohmic load
- Alarm holding time	2.5s
Tamper contact	30V _{DC} / 100mA (ohmic load)
RESET input	LOW ≤ 1.5V / HIGH ≥ 3.5V
Coverage area	
- Range	Max. 8.5m
- Sensitivity setting	8m = up to 8.5m radius 4m = up to 4m radius
- Size of the monitoring surface	Min. 0.3m x 0.3m Max. 6m x 6m
- Volume of the monitored room	Min. 22m ³ Max. 245m ³
- Approved glass type	Float glass (standard window glass) Min. 3mm Max. 6mm
Ambient conditions	
- Operation temperature	-10 ... +55°C
- Storage temperature	-20 ... +60°C
- Humidity (DIN40040)	< 95 % r.h., non condensing
- Housing protection EN60529, EN50102	IP31 / IK02
Approvals	VdS Class B, pending

Details for ordering

Type	Part no	Designation	Weight
AGB600	A5Q00001591	Audio glass break detector	0.150kg
GT2	507419	Glass break simulator for AGB600	0.250kg

Siemens Building Technologies AG
 Alte Landstr. 411
 CH-8708 Männedorf
 Tel. +41 1 - 922 6111
 Fax +41 1 - 922 6450
 www.sibt.com

© 2003 Copyright by
 Siemens Building Technologies AG
 Data and design subject to change without notice.
 Supply subject to availability.